

Distributed by Tri-State Equipment Company Inc. | sales@tsoverheadcrane.com | (314) 869-7200 | www.tsoverheadcrane.com

This document is the absolute property of R&M. This document must not be copied without the written permission of R&M. The contents thereof must not be disclosed to a third party nor be used for any unauthorized purpose. Contravention will be prosecuted.

REV	CHANGE DESCRIPTION	ECN	DATE	REVISED BY	APPROVED BY

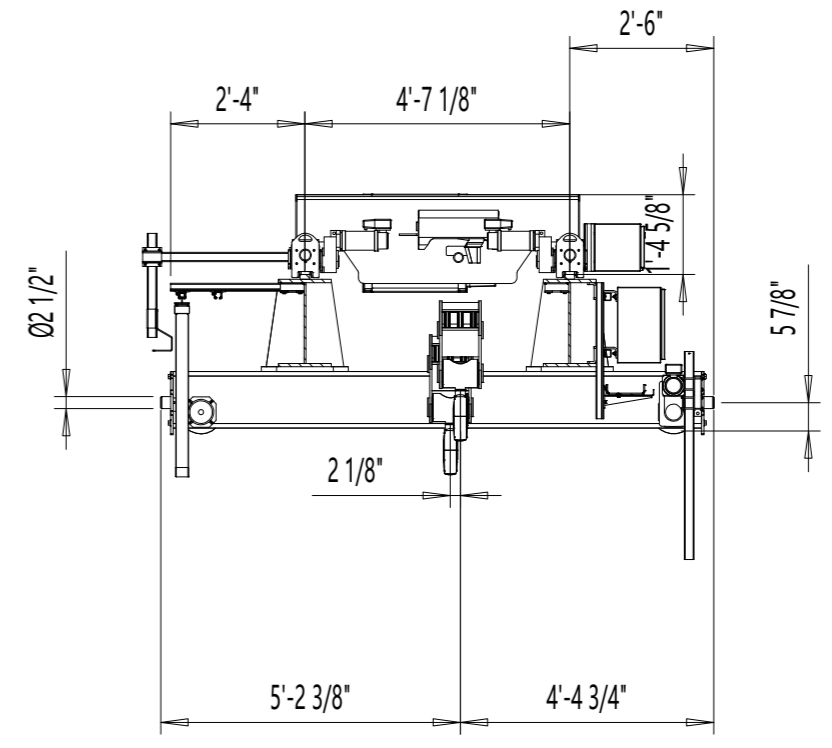
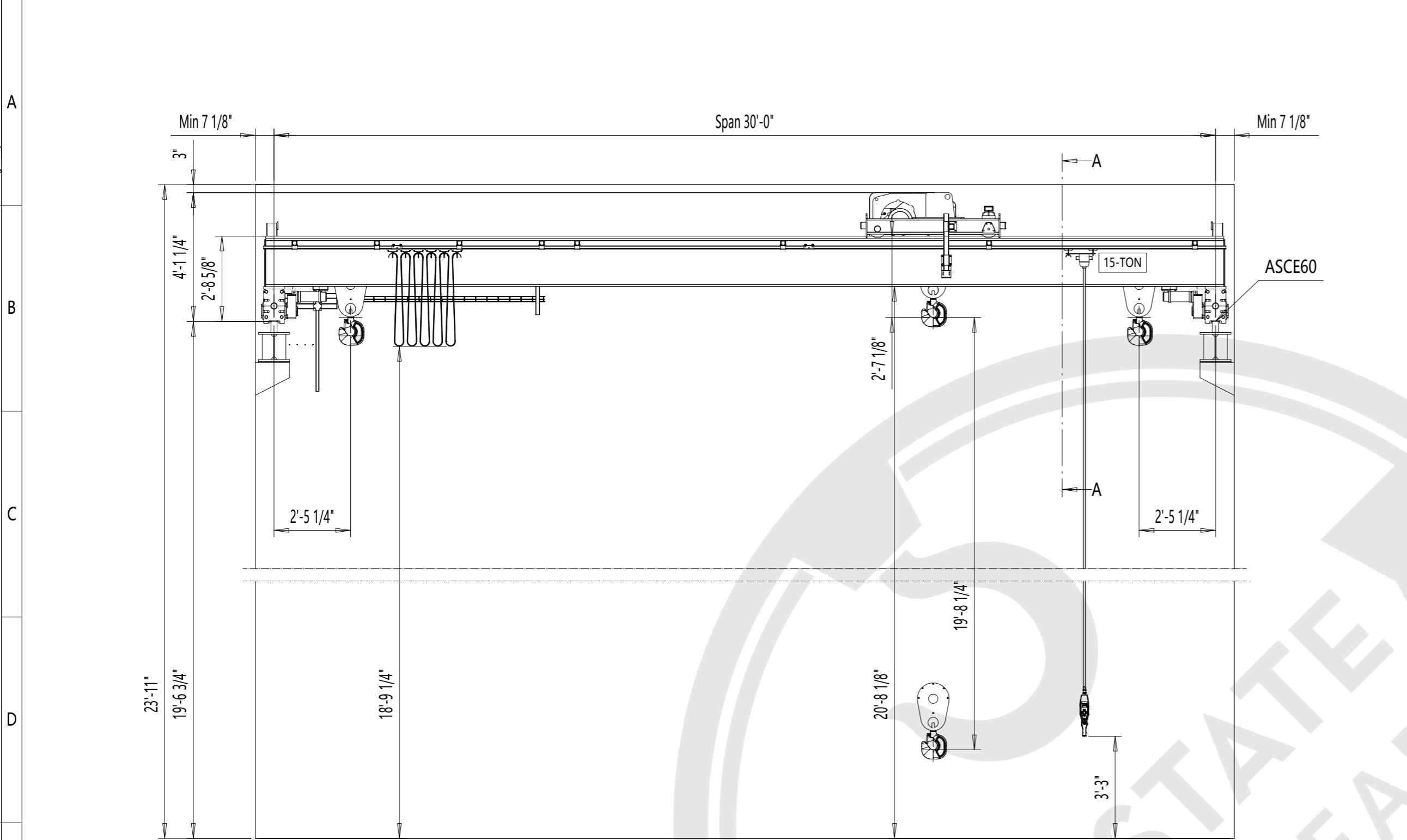

View A-A

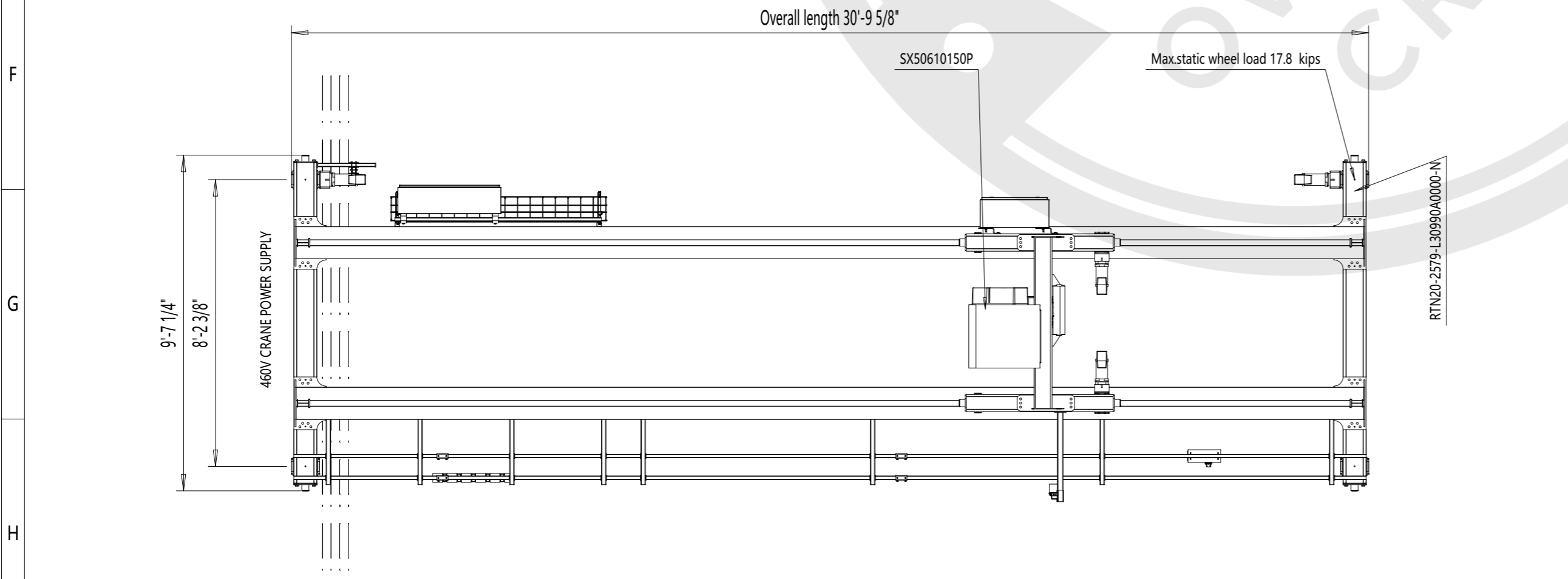
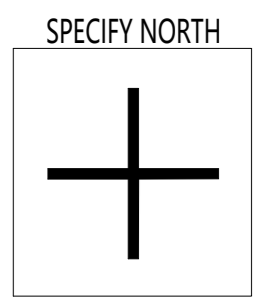

TECHNICAL DATA

Span	: 30'-0"
Load	: 15-TON
Lifting height	: 19'-8 1/4"
Hoisting speed	: 12.5/2.0 ft/min 2-speed
Traversing speed	: 65 ft/min stepless
Travelling speed	: 100 ft/min Stepless
Weight of trolley	: 1670 lbs
Weight of bridge	: 7173 lbs
Crane classification	: CMAA Class C
Hoist group	: ASME H4
Crane drive group	: CMAA C
Main / control voltage	: 460 / 115 V; 60 Hz
Supply power	: 17.57 Hp
Length of runway	: 0"

SURFACE TREATMENT OF CRANE

Bridge color	: Safety Yellow
Paint	: AKRYL /127 µm

Customer organizes safe Platform for crane service

Indoor Use crane 32°104° F

Pendant controlled crane: movable



Pos	Amount	Description	Specification
ACCEPTED BY:			
COMPANY:			
DATE:			
Distributed by:			
Tri-State Equipment Company Inc.			
sales@tsoverheadcrane.com			
www.tsoverheadcrane.com			
Tel: (314) 869-7200			
Design	Date	Dept	Vx proj
QXDka15-TON x 30ft Hol:19.69ft			
1:40			
M-film			
Issue			

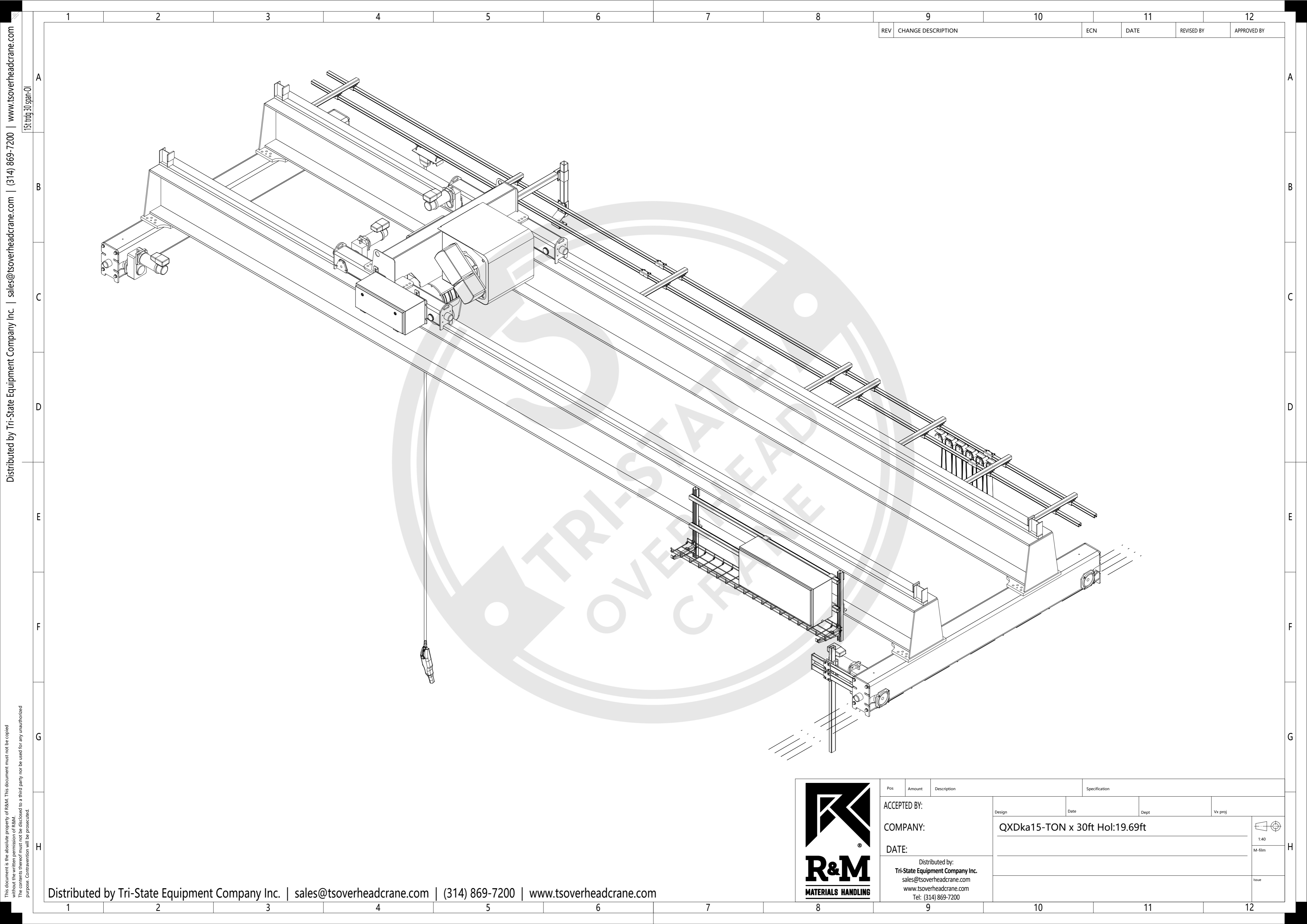

Distributed by Tri-State Equipment Company Inc. | sales@tsoverheadcrane.com | (314) 869-7200 | www.tsoverheadcrane.com
 15ft track 30 span-0

REV	CHANGE DESCRIPTION	ECN	DATE	REVISED BY	APPROVED BY
-----	--------------------	-----	------	------------	-------------

This document is the absolute property of R&M. This document must not be copied without the written permission of R&M. The contents thereof must not be disclosed to a third party nor be used for any unauthorized purpose. Contravention will be prosecuted.

Distributed by Tri-State Equipment Company Inc. | sales@tsoverheadcrane.com | (314) 869-7200 | www.tsoverheadcrane.com



Pos	Amount	Description	Specification
ACCEPTED BY:		Design	Date
COMPANY:		Dept	Vx proj
DATE:		QXDka15-TON x 30ft Hol:19.69ft	
Distributed by:		1:40	
Tri-State Equipment Company Inc.		M-film	
sales@tsoverheadcrane.com		Issue	
www.tsoverheadcrane.com			
Tel: (314) 869-7200			