

Distributed by Tri-State Equipment Company Inc. | sales@tsoverheadcrane.com | (314) 869-7200 | www.tsoverheadcrane.com

This document is the absolute property of R&M. This document must not be copied without the written permission of R&M. The contents thereof must not be disclosed to a third party nor be used for any unauthorized purpose. Contravention will be prosecuted.

REV	CHANGE DESCRIPTION	ECN	DATE	REVISED BY	APPROVED BY
-----	--------------------	-----	------	------------	-------------

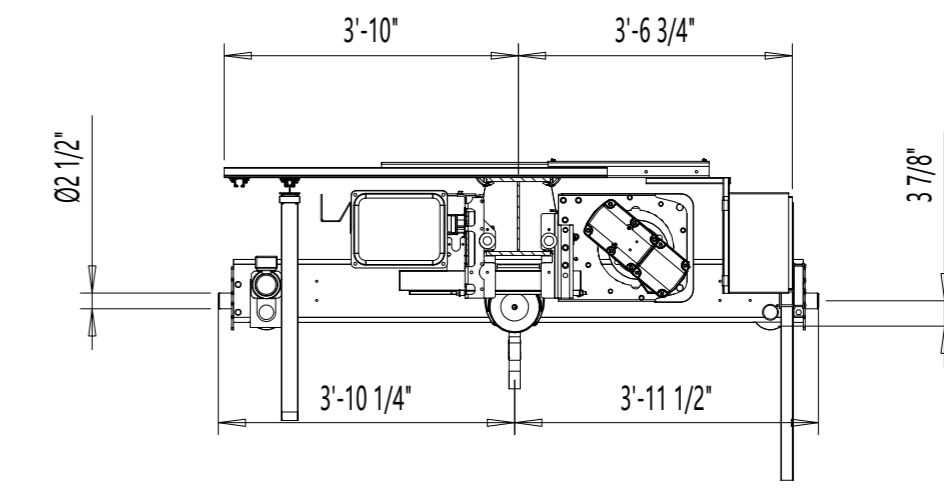
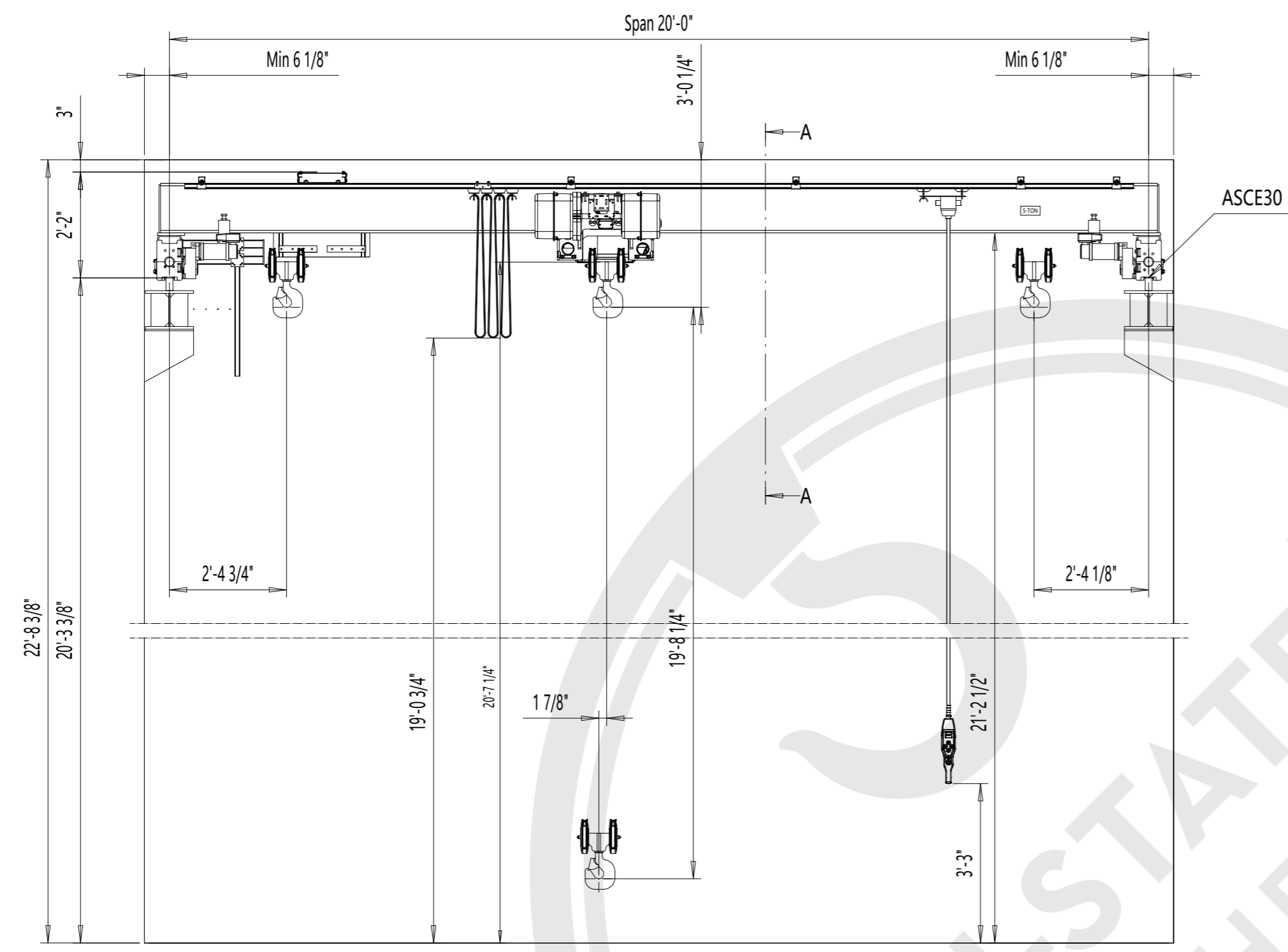

View A-A

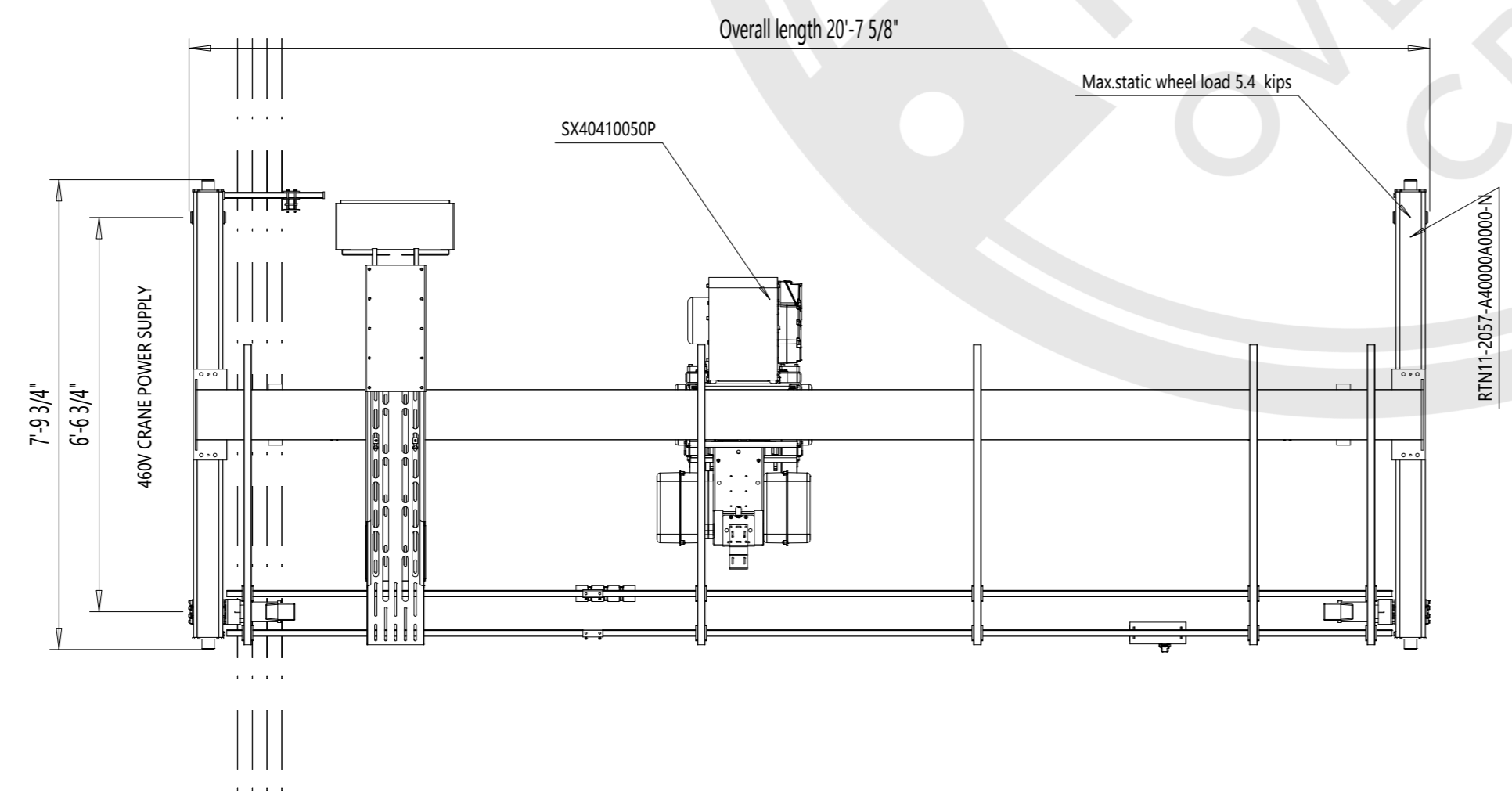
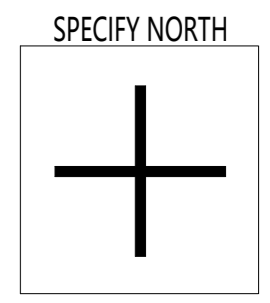

TECHNICAL DATA

Span	: 20'-0"
Load	: 5-TON
Lifting height	: 19'-8 1/4"
Hoisting speed	: 20.0/3.2 ft/min 2-speed
Traversing speed	: 65 ft/min stepless
Travelling speed	: 100 ft/min Stepless
Weight of trolley	: 820 lbs
Weight of bridge	: 2159 lbs
Crane classification	: CMAA Class C
Hoist group	: ASME H4
Crane drive group	: CMAA C
Main / control voltage	: 460 / 115 V; 60 Hz
Supply power	: 8.62 Hp
Length of runway	: 0"

SURFACE TREATMENT OF CRANE

Bridge color	: Safety Yellow
Paint	: AKRYL /127 μm

Customer organizes safe Platform for crane service

Indoor Use crane 32° 104° F

Pendant controlled crane: movable



Pos	Amount	Description	Specification
ACCEPTED BY:		Design	Date
COMPANY:		Dept	
DATE:		Vx proj	
Distributed by:		QXska5-TON x 20ft Hol:19.69ft	
Tri-State Equipment Company Inc.		1:30	
sales@tsoverheadcrane.com		M-film	
www.tsoverheadcrane.com		Issue	
Tel: (314) 869-7200			

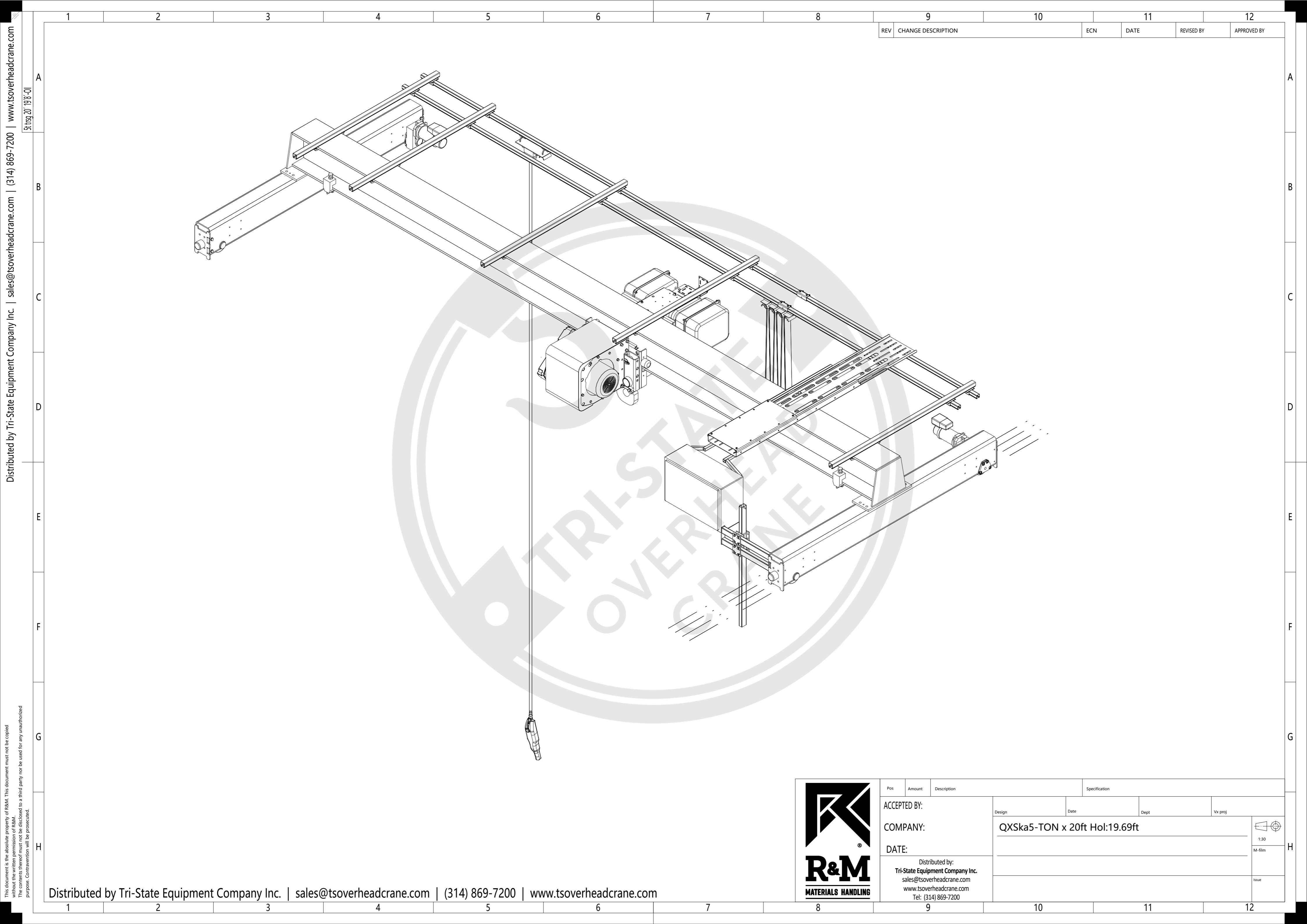

Distributed by Tri-State Equipment Company Inc. | sales@tsoverheadcrane.com | (314) 869-7200 | www.tsoverheadcrane.com
 5/13/20 19:00

This document is the absolute property of R&M. This document must not be copied without the written permission of R&M. The contents thereof must not be disclosed to a third party nor be used for any unauthorized purpose. Contravention will be prosecuted.

REV	CHANGE DESCRIPTION	ECN	DATE	REVISED BY	APPROVED BY
-----	--------------------	-----	------	------------	-------------



Pos	Amount	Description	Specification
ACCEPTED BY:		Design	Date
COMPANY:		Dept	
DATE:		Vx proj	
Distributed by:		QXska5-TON x 20ft HoI:19.69ft	
Tri-State Equipment Company Inc.		1:30	
sales@tsoverheadcrane.com		M-film	
www.tsoverheadcrane.com		Issue	
Tel: (314) 869-7200			