

View A-A

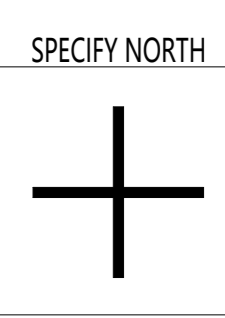

This document is the absolute property of R&M. This document must not be copied without the written permission of R&M. The contents thereof must not be disclosed to a third party nor be used for any unauthorized purpose. Contravention will be prosecuted.

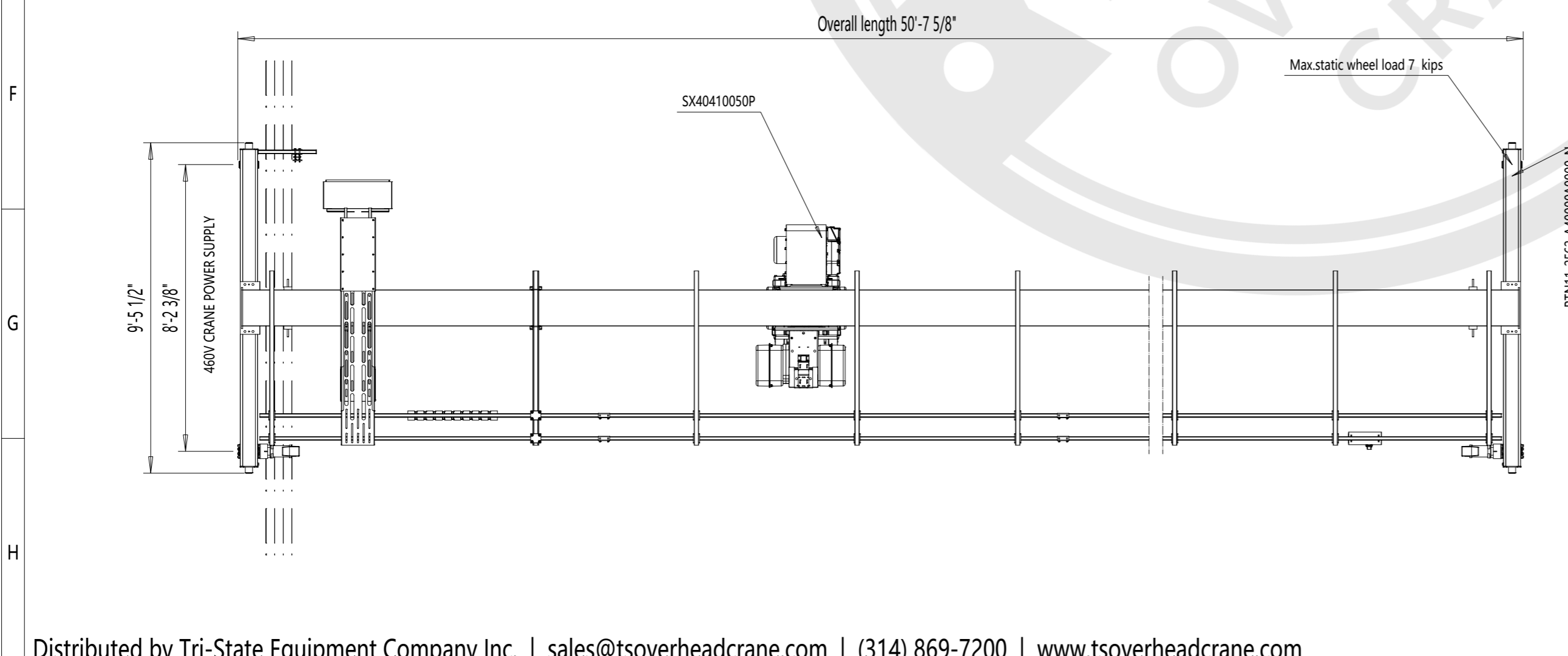

TECHNICAL DATA	
Span	: 50'-0"
Load	: 5-TON
Lifting height	: 19'-8 1/4"
Hoisting speed	: 20.0/3.2 ft/min 2-speed
Traversing speed	: 65 ft/min stepless
Travelling speed	: 100 ft/min Stepless
Weight of trolley	: 770 lbs
Weight of bridge	: 7029 lbs
Crane classification	: CMAA Class C
Hoist group	: ASME H4
Crane drive group	: CMAA C
Main / control voltage	: 460 / 115 V; 60 Hz
Supply power	: 8.57 Hp
Length of runway	: 0"

SURFACE TREATMENT OF CRANE	
Bridge color	: Safety Yellow
Paint	: AKRYL / 127 µm
Customer organizes safe Platform for crane service	
Indoor Use crane 32° .... 104° F	
Pendant controlled crane: movable	

	Pos	Amount	Description	Specification
	ACCEPTED BY:		Design	Date
	COMPANY:		Dept	Vx proj
DATE:		QXska5-TON x 50ft Hol:19.69ft		1:40
Distributed by: Tri-State Equipment Company Inc. sales@tsoverheadcrane.com www.tsoverheadcrane.com Tel: (314) 869-7200				M-film
				Issue

Distributed by Tri-State Equipment Company Inc. | sales@tsoverheadcrane.com | (314) 869-7200 | www.tsoverheadcrane.com

This document is the absolute property of R&M. This document must not be copied without the written permission of R&M. The contents thereof must not be disclosed to a third party nor be used for any unauthorized purpose. Contravention will be prosecuted.

REV	CHANGE DESCRIPTION	ECN	DATE	REVISED BY	APPROVED BY

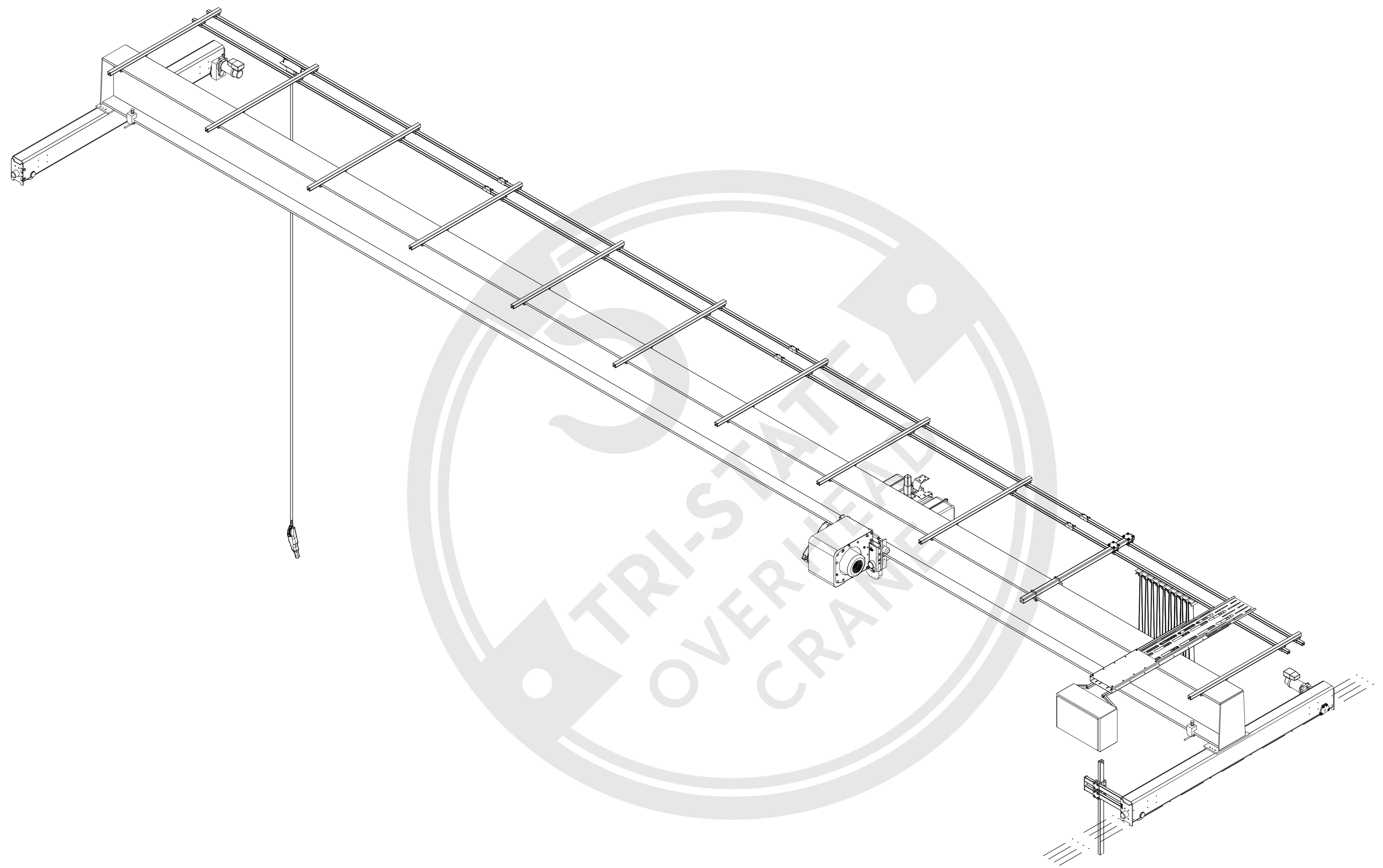

Distributed by Tri-State Equipment Company Inc. | sales@tsoverheadcrane.com | (314) 869-7200 | www.tsoverheadcrane.com



Pos	Amount	Description	Specification
ACCEPTED BY:		Design	Date
COMPANY:		Dept	
DATE:		Vx proj	
Distributed by:		1:40	
Tri-State Equipment Company Inc.		M-film	
sales@tsoverheadcrane.com		Issue	
www.tsoverheadcrane.com			
Tel: (314) 869-7200			

Design	Date	Dept	Vx proj
QXska5-TON x 50ft Hol:19.69ft			