

Distributed by Tri-State Equipment Company Inc. | sales@tsoverheadcrane.com | (314) 869-7200 | www.tsoverheadcrane.com

This document is the absolute property of R&M. This document must not be copied without the written permission of R&M. The contents thereof must not be disclosed to a third party nor be used for any unauthorized purpose. Contravention will be prosecuted.

REV	CHANGE DESCRIPTION	ECN	DATE	REVISED BY	APPROVED BY
-----	--------------------	-----	------	------------	-------------

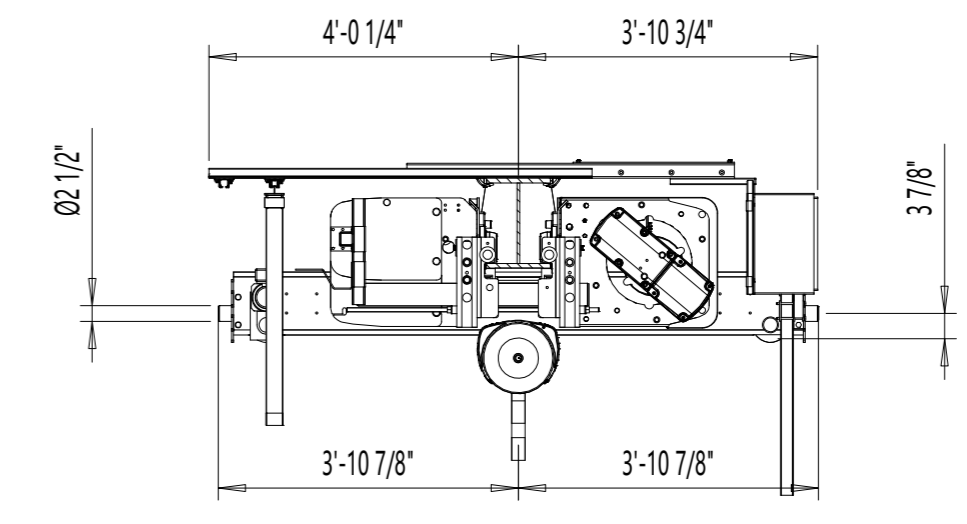
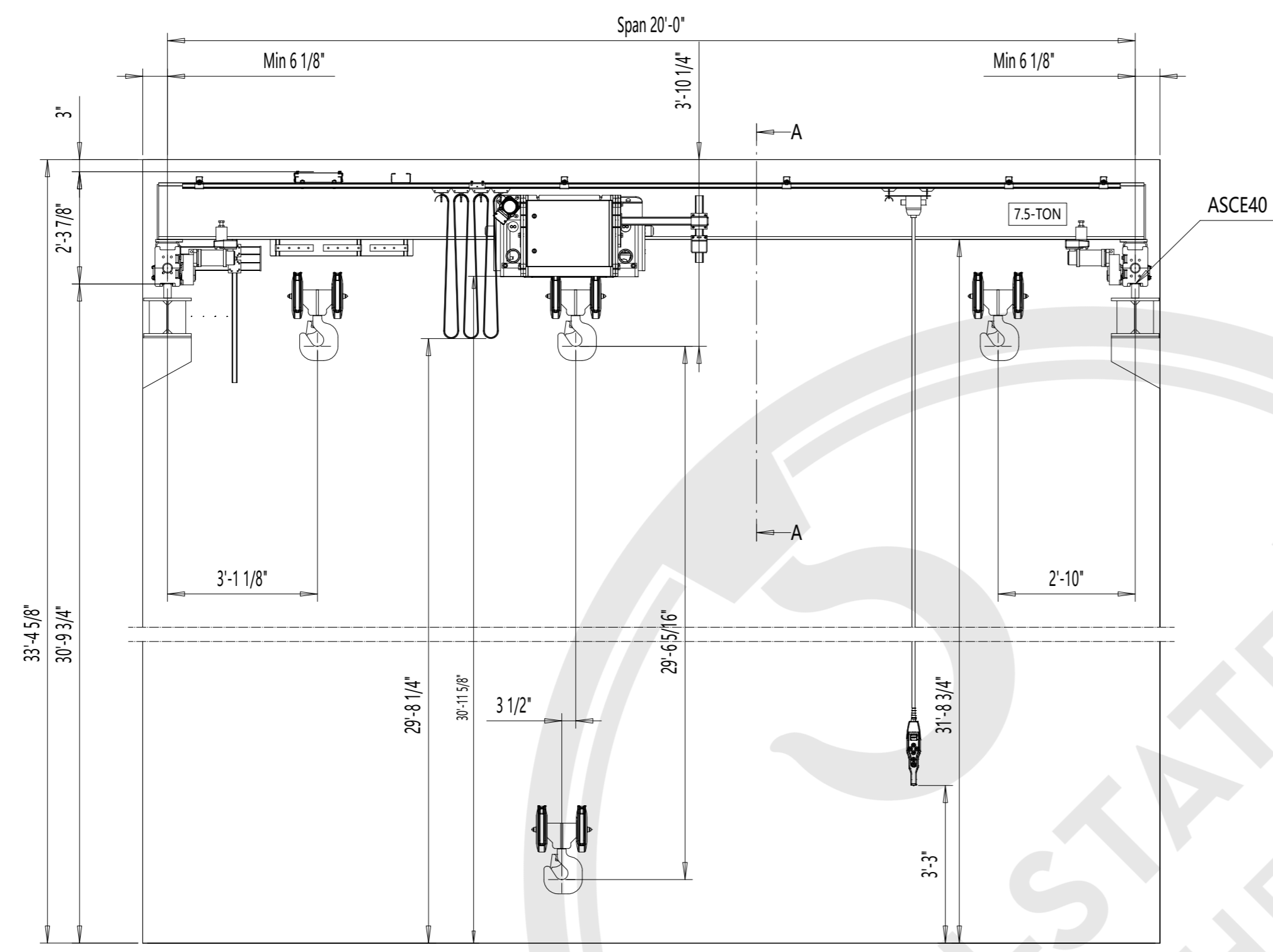

View A-A

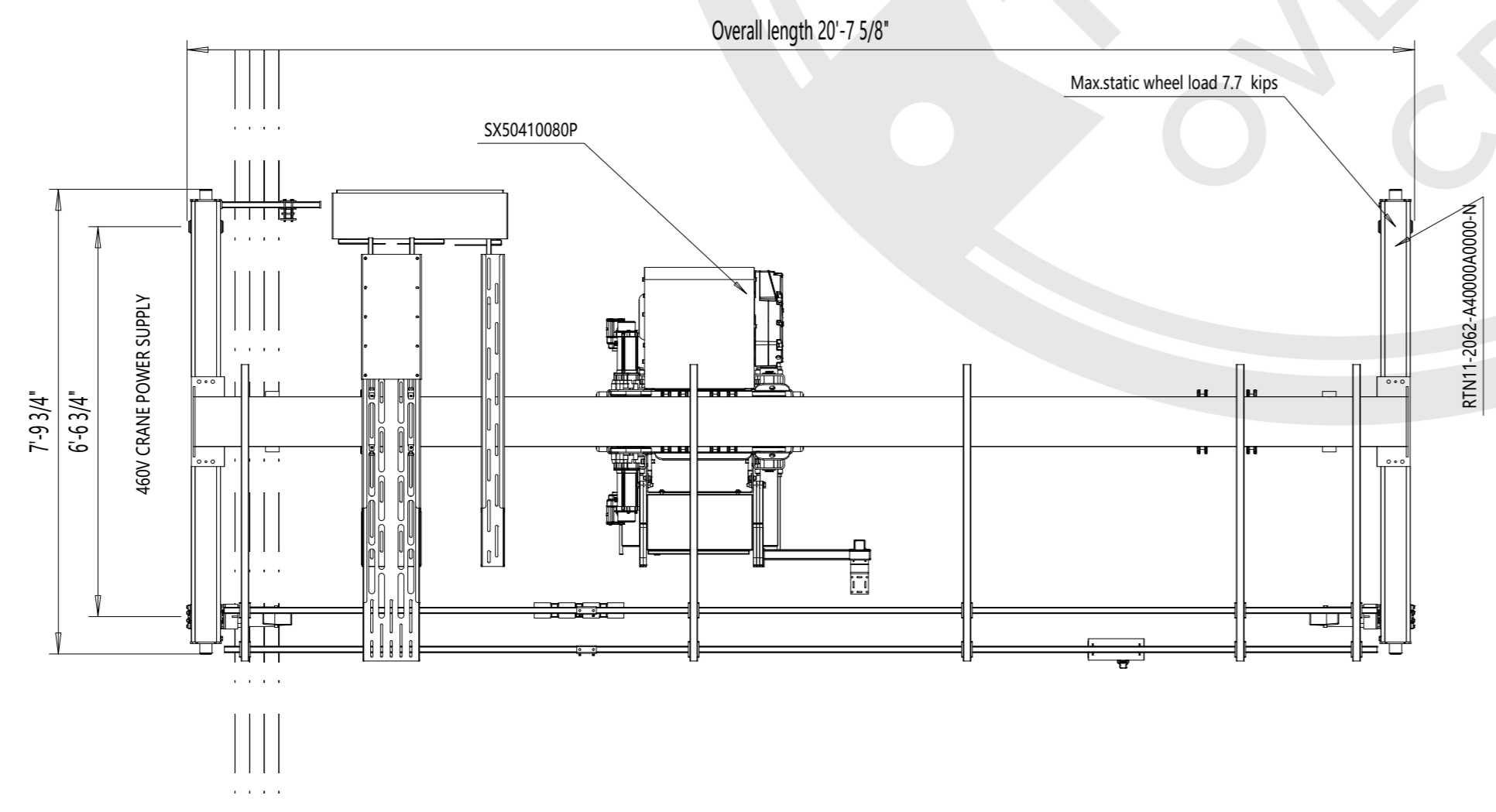
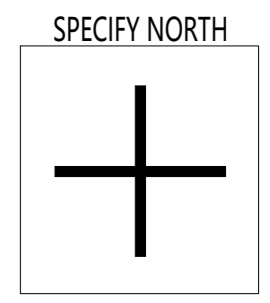

TECHNICAL DATA

Span	: 20'-0"
Load	: 7.5-TON
Lifting height	: 29'-6 5/16"
Hoisting speed	: 20.0/3.2 ft/min 2-speed
Traversing speed	: 65 ft/min stepless
Travelling speed	: 100 ft/min Stepless
Weight of trolley	: 1440 lbs
Weight of bridge	: 2373 lbs
Crane classification	: CMAA Class C
Hoist group	: ASME H4*
Crane drive group	: CMAA C
Main / control voltage	: 460 / 115 V; 60 Hz
Supply power	: 16.7 Hp
Length of runway	: 0"

SURFACE TREATMENT OF CRANE

Bridge color	: Safety Yellow
Paint	: AKRYL /127 µm

Customer organizes safe Platform for crane service

Indoor Use crane 32° 104° F

Pendant controlled crane: movable



Pos	Amount	Description	Specification
ACCEPTED BY:		Design	Date
COMPANY:		QXska7.5-TON x 20ft Hol:29.53ft	
DATE:		Dept	Vx proj
Distributed by:		1:30	
Tri-State Equipment Company Inc.		M-film	
sales@tsoverheadcrane.com		Issue	
www.tsoverheadcrane.com			
Tel: (314) 869-7200			

REV	CHANGE DESCRIPTION	ECN	DATE	REVISED BY	APPROVED BY
-----	--------------------	-----	------	------------	-------------

Distributed by Tri-State Equipment Company Inc. | sales@tsoverheadcrane.com | (314) 869-7200 | www.tsoverheadcrane.com
 7.5t (16,500 lb)

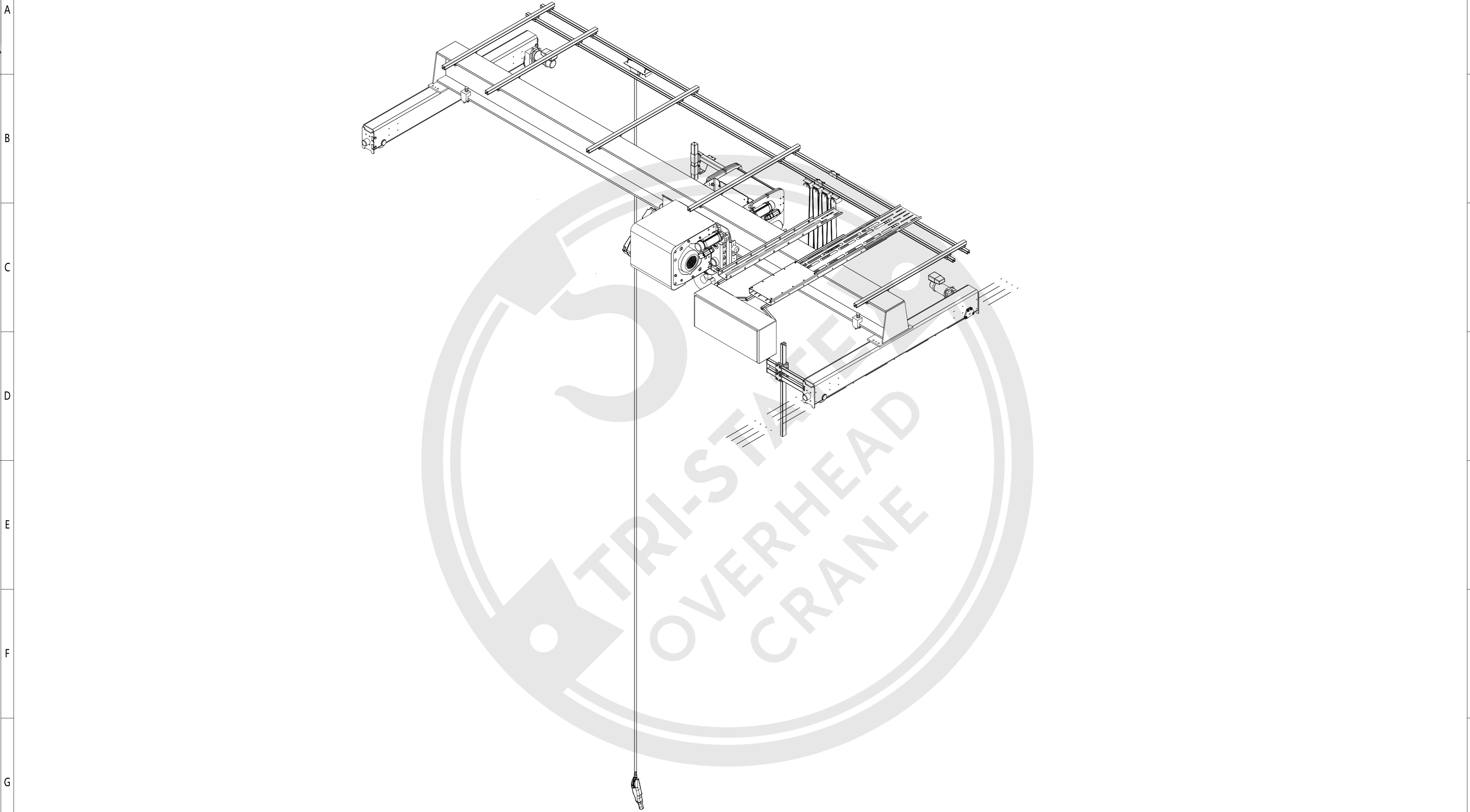

This document is the absolute property of R&M. This document must not be copied without the written permission of R&M. The contents thereof must not be disclosed to a third party nor be used for any unauthorized purpose. Contravention will be prosecuted.



Pos	Amount	Description	Specification
ACCEPTED BY:		Design	Date
COMPANY:		Dept	Vx proj
DATE:		QXSk7.5-TON x 20ft Hol:29.53ft	
Distributed by: Tri-State Equipment Company Inc. sales@tsoverheadcrane.com www.tsoverheadcrane.com Tel: (314) 869-7200		1:30 M-film	
		Issue	