

# MODEL 84A/PT TROLLEY

## Service Instructions and Parts List

Section O/T3, P01

1/4 Thru 3 Ton

### CAUTION:

THE EQUIPMENT ILLUSTRATED AND DESCRIBED IN THIS BULLETIN IS DESIGNED FOR MANUAL OPERATION ONLY AND IS NOT TO BE POWER DRIVEN, NOR IS IT SUITABLE FOR TRANSPORTING PERSONS!

The Model 84A/PT trolley is a relatively simple mechanism requiring comparatively little care, maintenance, inspection and lubrication. The following information is provided to assist in installing and maintaining this equipment.

### INSTALLATION

Sliding the trolley over the open end of the runway beam is the simplest way to install this unit. If an open beam end is not available, one side plate can be removed and the unit can be reassembled on the beam. Always verify the trolley is adjusted properly to fit the beam. See the adjustment instructions below. Always run the unit along the entire length of the runway beam to verify proper operation and clearances.

### GENERAL MAINTENANCE

Thorough inspection is recommended at regular intervals. The frequency of inspection must be determined by the user, since application factors such as duty cycle and ambient conditions will dictate the maintenance requirements of the unit. When inspections are made, the entire trolley should be inspected for wear, or for damage such as may be sustained through severe overloading or impact with other objects. Replace all damaged parts immediately. Check trolley motion along the runway beam, to verify proper operation.

### LUBRICATING THE TROLLEY

1/4 thru 3 ton 84A/PT Trolleys are built with sealed, life-time lubricated precision ball bearings that should require no further lubrication. Periodic lubrication of the trolley drive shaft support block and the handwheel guard is recommended. A small amount of lithium based NLGI Grade 2 grease should be applied through the grease fittings provided.

### WARNING:

DO NOT transport loads over people.  
DO NOT operate the trolley unless you are physically fit and trained to do so.  
NEVER load the trolley beyond its rated capacity.  
DO NOT leave a load suspended for long periods of time.

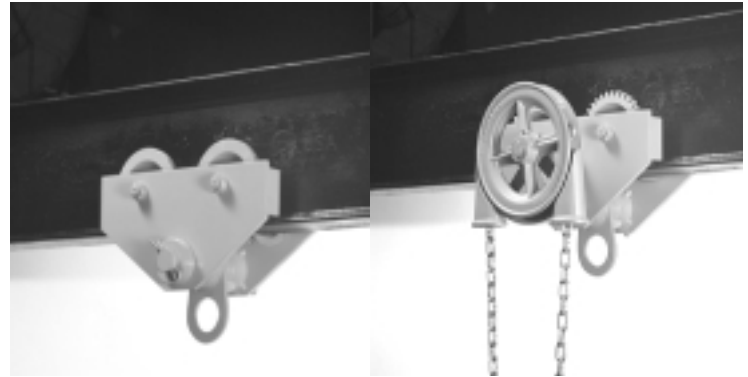

PLAIN TROLLEY

GEARED TROLLEY

### ADJUSTMENT INSTRUCTIONS:

Beam flange width plus 1/16" running clearance on each side of the flange is the correct trolley setting. Move the spacing washers to the inside or outside of the plates as required.

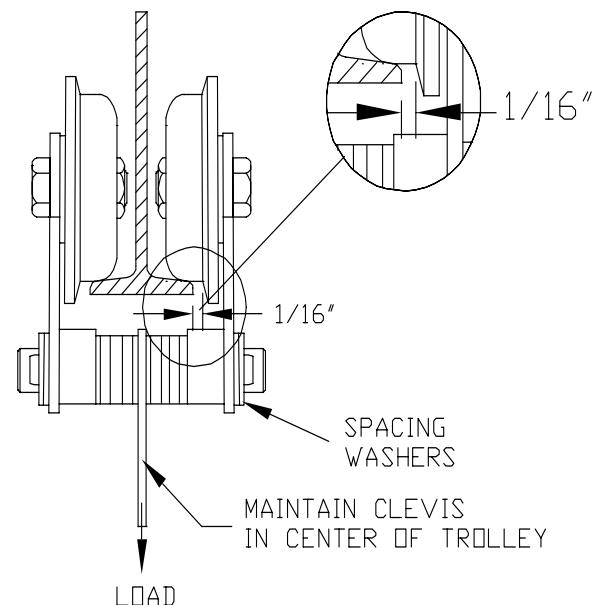

### WARNING:

DO fit all open beam ends with trolley stops.  
DO make sure there are no objects in the way of the moving load.  
DO NOT leave a load unattended.  
NEVER allow a load to swing off center.  
NEVER lift an off center load.

# 1/4 THRU 3 TON CAPACITY 84A/PT TROLLEY PARTS LIST

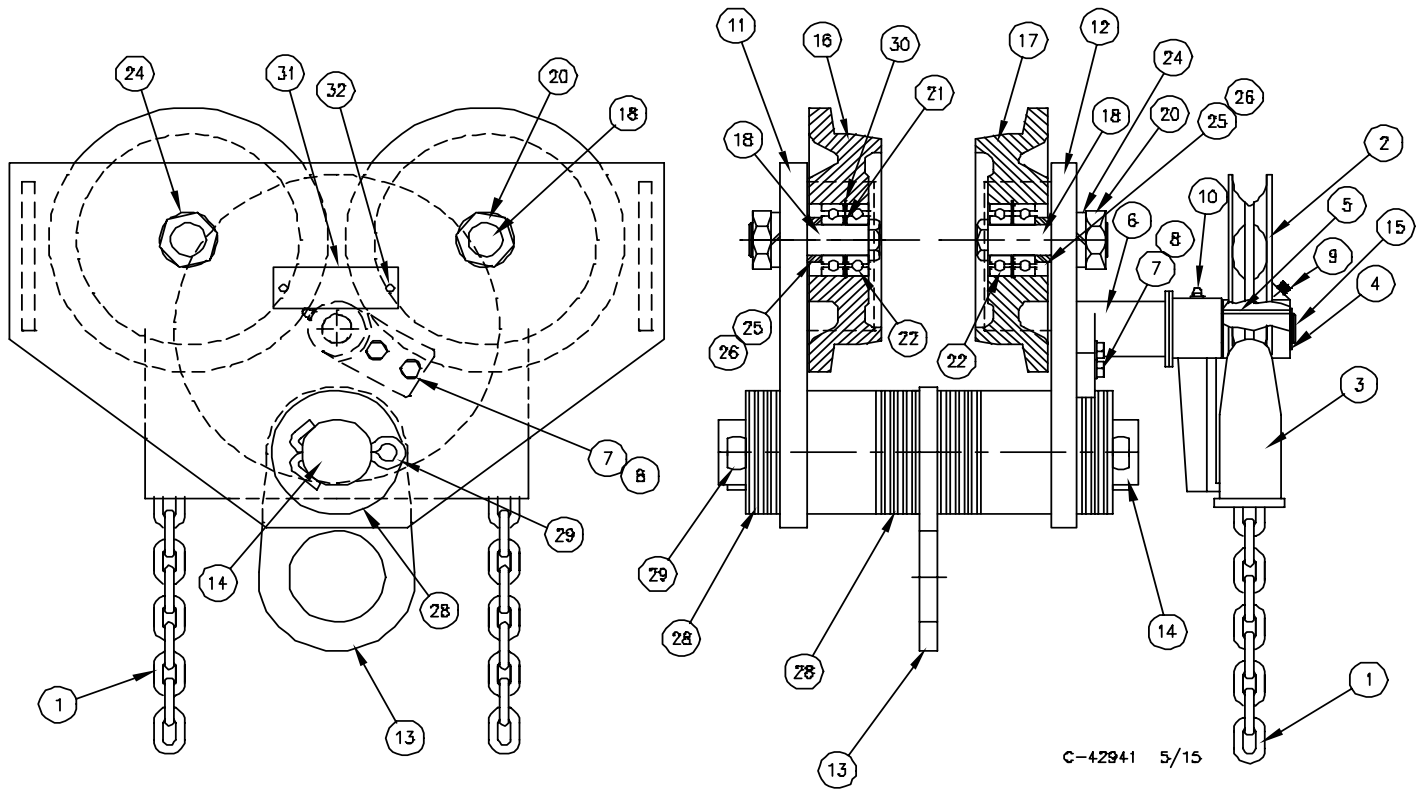

ITEM NO	ITEM DESCRIPTION	1/4 AND 1/2 TON		1 TON		1-1/2 TON		2 TON		3 TON	
		PART NO	QTY	PART NO	QTY	PART NO	QTY	PART NO	QTY	PART NO	QTY
1	HAND CHAIN	C33029	?(0)	C33029	?(0)	C33029	?(0)	C937	?(0)	C937	?(0)
1	CONNECTING LINK	C33029L	1(0)	C33029L	1(0)	C33029L	1(0)	C937L	1(0)	C937L	1(0)
2	HANDWHEEL	C36072P1	1(0)	C36072P1	1(0)	C36072P1	1(0)	C9120-0075P1	1(0)	C9120-0075P1	1(0)
3	HANDWHEEL GUARD	C37175P1	1(0)	C37175P1	1(0)	C37175P1	1(0)	C9121-0075P1	1(0)	C9121-0075P1	1(0)
4	SNAP RING (EXT)	5100-87	1(0)	5100-87	1(0)	5100-87	1(0)	5100-87	1(0)	5100-87	1(0)
5	KEY	13-.25-1.50	1(0)	13-.25-1.50	1(0)	13-.25-1.50	1(0)	13-.25-1.50	1(0)	13-.25-1.50	1(0)
6	SUPPORT BLOCK	C35494	1(0)	C35494	1(0)	C35494	1(0)	C35494	1(0)	C35494	1(0)
7	LOCKWASHER	1-.31	2(0)	1-.31	2(0)	1-.31	2(0)	1-.31	2(0)	1-.31	2(0)
8	CAP SCREW	14-.31-1.00	2(0)	14-.31-1.00	2(0)	14-.31-1.00	2(0)	14-.31-1.00	2(0)	14-.31-1.00	2(0)
9	SET SCREW	58-.25-.87	1(0)	58-.25-.87	1(0)	58-.25-.87	1(0)	58-.25-.87	1(0)	58-.25-.87	1(0)
10	GREASE FITTING	1743B	2(0)	1743B	2(0)	1743B	2(0)	1743B	2(0)	1743B	2(0)
11	PLAIN SIDE PLATE	C42915	1	C42917	1	C42917	1	C42919	1	C42919	1
12	GEARED SIDE PLATE	C42915G	1	C42917G	1	C42917G	1	C42919G	1	C42919G	1
13	CLEVIS	C42926P1	1	C42926P2	1	C42926P3	1	C42926P4	1	C42926P5	1
14	EQUILIZING PIN	C42927P1	1	C42927P2	1	C42927P2	1	C42927P3	1	C42927P3	1
15	DRIVE SHAFT	C154A0025	1(0)	C154A0025	1(0)	C154A0025	1(0)	C154A0025	1(0)	C154A0025	1(0)
16	PLAIN WHEEL	C37000-26	2(4)	C37001-1	2(4)	C37001-1	2(4)	C37002-1	2(4)	C37002-1	2(4)
17	GEARED WHEEL	C37000-26G	2(0)	C37001-1G	2(0)	C37001-1G	2(0)	C37002-1G	2(0)	C37002-1G	2(0)
18	AXLE	C9110-0025	4	C9110-0025	4	C9110-0025	4	C9110-0150	4	C9110-0150	4
20	NUT	98-.62-2	4	98-.62-2	4	98-.62-2	4	96-.75-2	4	96-.75-2	4
21	BEARING SPACER	C23854	4	C23854	4	C23854	4	C23855	4	C23855	4
22	BEARING	C9107-0050	8	C9107-0050	8	C9107-0050	8	C9107-0150	8	C9107-0150	8
24	LOCKWASHER	1-.62	4	1-.62	4	1-.62	4	1-.75	4	1-.75	4
25	WHL SPACER(THK)	C9303-0025	16	C9303-0025	16	C9303-0025	16	C9303-0100	12	C9303-0100	12
26	WHL SPACER(THN)	N.A.	0	N.A.	0	N.A.	0	C9303A0100	4	C9303A0100	4
28	WASHER	2-1.00	27	C99903	32	C99903	32	C99915	29	C99915	29
29	COTTER PIN	128-.31-1.50	2	128-.31-1.75	2	128-.31-1.75	2	128-.37-2.50	2	128-.37-2.50	2
30	SNAP RING (INT)	5000-137	4	5000-137	4	5000-137	4	5000-175	4	5000-175	4
31	SERIAL NO TAG	SNT-PTG(P)	1	SNT-PTG(P)	1	SNT-PTG(P)	1	SNT-PTG(P)	1	SNT-PTG(P)	1
32	RIVETS	142-4-.25	2	142-4-.25	2	142-4-.25	2	142-4-.25	2	142-4-.25	2

NOTE: QUANTITIES SHOWN FOR GEARED UNITS. PLAIN QUANTITIES ARE SHOWN IN BRACKETS ( ).