

Installation, Operation, & Maintenance Manual

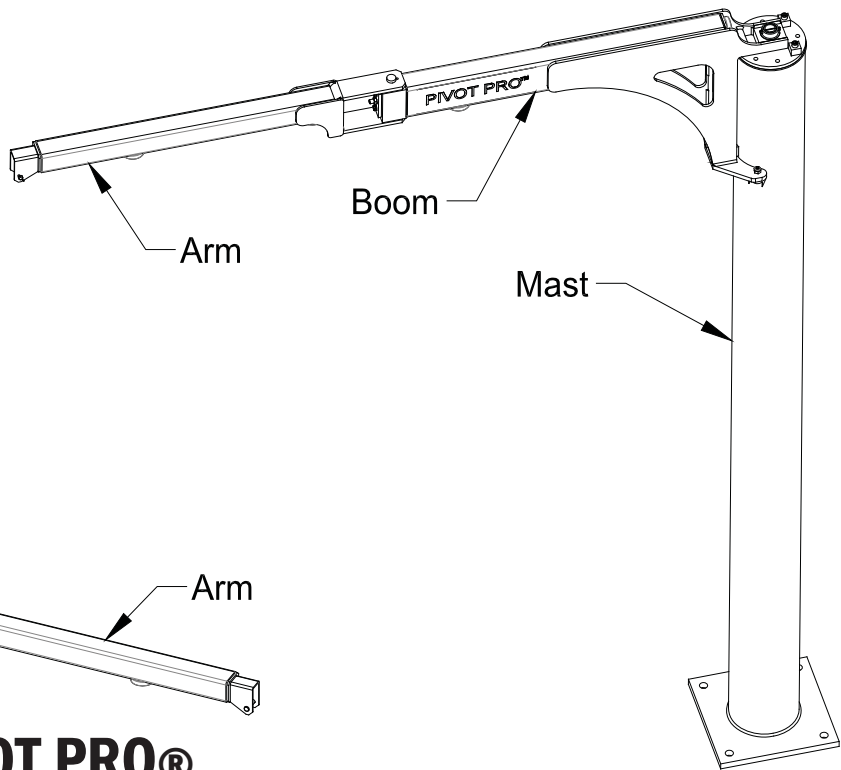

Free Standing PIVOT PRO®

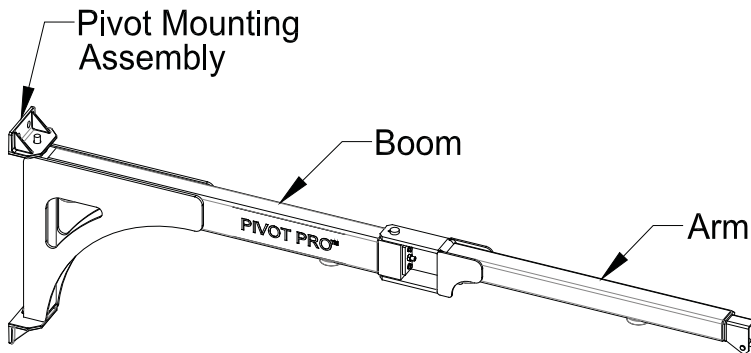

Wall Mounted PIVOT PRO®

**IMPORTANT!
DO NOT DESTROY**

PIVOT PRO® **Articulating Jib Crane**

Gorbel® Customer Order No. / Serial No. _____

Gorbel® Dealer _____

Date _____
Month _____ Year _____

Capacity	A	Span	Model Number T =Top hose connection B= Back hose connection	Anchor Bolt Load
50#	10'	8'	PPRO-FS-50-10-8-T PPRO-FS-50-10-8-B	528#
		10'	PPRO-FS-50-10-10-T PPRO-FS-50-10-10-B	720#
		12'	PPRO-FS-50-10-12-T PPRO-FS-50-10-12-B	927#
	12'	8'	PPRO-FS-50-12-8-T PPRO-FS-50-12-8-B	517#
		10'	PPRO-FS-50-12-10-T PPRO-FS-50-12-10-B	709#
		12'	PPRO-FS-50-12-12-T PPRO-FS-50-12-12-B	916#
75#	10'	8'	PPRO-FS-75-10-8-T PPRO-FS-75-10-8-B	668#
		10'	PPRO-FS-75-10-10-T PPRO-FS-75-10-10-B	897#
		12'	PPRO-FS-75-10-12-T PPRO-FS-75-10-12-B	1142#
	12'	8'	PPRO-FS-75-12-8-T PPRO-FS-75-12-8-B	656#
		10'	PPRO-FS-75-12-10-T PPRO-FS-75-12-10-B	886#
		12'	PPRO-FS-75-12-12-T PPRO-FS-75-12-12-B	1131#
100#	10'	8'	PPRO-FS-100-10-8-T PPRO-FS-100-10-8-B	807#
		10'	PPRO-FS-100-10-10-T PPRO-FS-100-10-10-B	1074#
		12'	PPRO-FS-100-10-12-T PPRO-FS-100-10-12-B	1356#
	12'	8'	PPRO-FS-100-12-8-T PPRO-FS-100-12-8-B	796#
		10'	PPRO-FS-100-12-10-T PPRO-FS-100-12-10-B	1063#
		12'	PPRO-FS-100-12-12-T PPRO-FS-100-12-12-B	1345#
150#	10'	8'	PPRO-FS-150-10-8-T PPRO-FS-150-10-8-B	1086#
		10'	PPRO-FS-150-10-10-T PPRO-FS-150-10-10-B	1428#
		12'	PPRO-FS-150-10-12-T PPRO-FS-150-10-12-B	1785#
	12'	8'	PPRO-FS-150-12-8-T PPRO-FS-150-12-8-B	1075#
		10'	PPRO-FS-150-12-10-T PPRO-FS-150-12-10-B	1417#
		12'	PPRO-FS-150-12-12-T PPRO-FS-150-12-12-B	1774#

Chart 1B. Chart for determining anchor bolt load of Free Standing PIVOT PRO®.

Note: Loads are based on a 50% impact factor and a maximum lift tube weight of 40 lbs.

WARNING

Consult a qualified structural engineer if you deviate from the recommended dimensions provided in this manual. Gorbel, Inc. is not responsible for any deviation from these foundation recommendations.

STEP 6 - ACCESSORIES (OPTIONAL) INSTALLATION

WARNING

NEVER place base on an uneven surface.

WARNING

ALWAYS remove load and secure boom prior to moving base.

WARNING

When moving, NEVER elevate portable base more than a few inches above the floor or ground surface.

WARNING

NEVER lift loads greater than specified for the base/jib combination (table 6.1).

6.1 INSTALLING PORTABLE BASE (diagram 6A)

- A) Verify the portable base is the correct size for the span and capacity PIVOT PRO®. Measure the base square width and thickness and refer to (**table 6.1, page 14**) for allowable capacities and corresponding spans. **NEVER use the optional portable base for a PIVOT PRO® with a higher capacity and corresponding span.** Derated capacity labels are available from Gorbel.
- B) Place portable base on an even surface capable of supporting the combined weight of the base, jib, and load.
- C) Level base using adjustment feet by loosening top nut and raising or lowering bottom nut. Repeat this for each foot until base is level. The base **MUST BE** supported by all four adjustable feet and **NOT** by the fork pockets. Tighten jam top nut.
- D) Secure boom (or assemble mast to base prior to boom assembly).
- E) Lower mast onto protruding bolts of base.
- F) Assemble flat washers, lock washers and nuts as shown. Tighten to 175 ft-lbs. Check for boom drift and adjust feet as required.
- G) When moving base and jib, make sure pallet jack or fork truck has sufficient capacity to lift load.
- H) Always use fork pockets in base to squarely position forks of pallet jack or fork truck.
- I) Do not tilt base while lifting and moving.

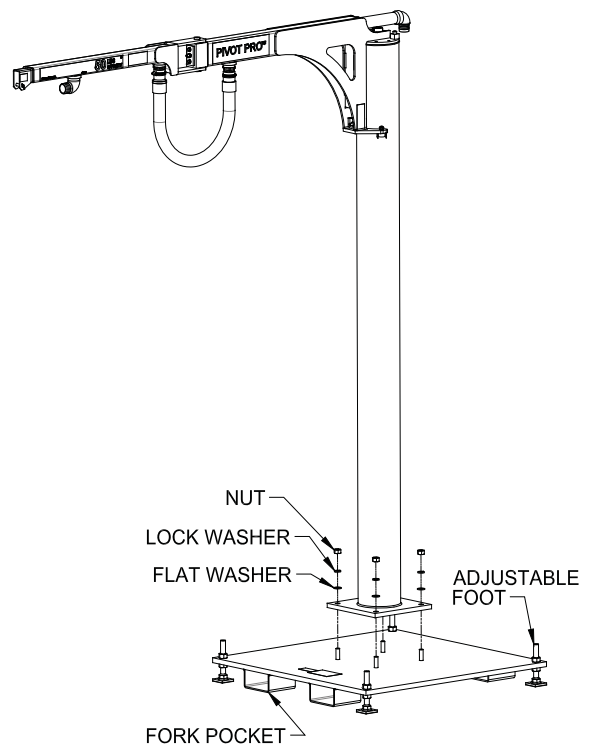

Diagram 6A. Installing portable base

STEP 6 - ACCESSORIES (OPTIONAL) INSTALLATION

SPAN	CAPACITY	50#	75#	100#	150#
8'	Model Number	PB-48-10	PB-48-10	PB-48-12	PB-54-12
	Square Length	48"	48"	48"	54"
	Thickness	1"	1"	1.25"	1.25"
	Shipping Weight	696#	696#	858#	1098#
10'	Model Number	PB-48-10	PB-48-12	PB-54-12	PB-60-12
	Square Length	48"	48"	54"	60"
	Thickness	1"	1.25"	1.25"	1.25"
	Shipping Weight	696#	858#	1098#	1363#
12'	Model Number	PB-48-12	PB-54-12	PB-60-12	PB-60-15
	Square Length	48"	54"	60"	60"
	Thickness	1.25"	1.25"	1.25"	1.5"
	Shipping Weight	858#	1098#	1363#	1617#

Table 6.1. Portable Base & Jib compatibility

6.2 INSTALLING BLOWER PLATFORM (*diagram 6B*)

- Transfer blower mounting pattern to the blower platform. Allow room for hose connections. Verify blower mounting hole locations are far enough away from blower platform verticals to allow for mounting hardware.
- Drill top of platform for blower mounting.
- Position blower platform on mast and align 3/8"-16 tapped holes in mast with countersunk holes in blower platform verticals. Note, two strap slots are provided in the platform to assist in positioning.
- Install 3/8"-16 x 3/4" long flat head cap screws with 7/32" allen wrench. Tighten to 20 ft-lbs.
- Position blower onto platform and continue connections as required per blower manufacturer's instructions.

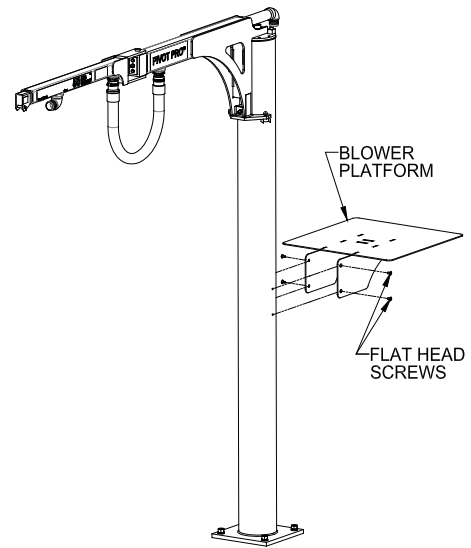

Diagram 6B. Installing blower platform

6.3 INSTALLING FILTER BRACKET (*diagram 6C*)

The filter bracket allows for weld-free mounting of the blower filter. Review the filter manufacturer's instructions for proper filter orientation. The filter bracket can be mounted vertically or horizontally depending on the filter's bolt hole locations.

- Transfer filter mounting pattern to the filter bracket.
- Drill filter bracket for filter mounting.
- Position filter bracket on mast and align 3/8"-16 tapped hole in mast with countersunk hole in filter bracket.
- Install 3/8"-16 x 1-1/2" long flat head cap screws with 7/32" allen wrench. Tighten to 20 ft-lbs.
- Position filter on bracket and continue connections as required per filter manufacturer's instructions.

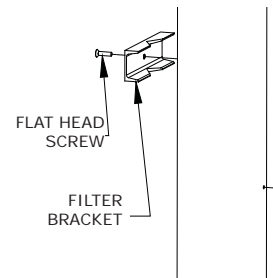

Diagram 6C. Installing filter bracket

STEP 6 - ACCESSORIES (OPTIONAL) (CONTINUED)

6.4 INSTALLING SMART HOOK (diagram 6D)

Smart Hook provides a convenient location to place your lift tube controls and head when not in use.

- A) Position Smart Hook on mast and align 5/16"-18 tapped hole in mast with hole in filter bracket.
- B) Install 5/16"-18 x 3/4" long hex head cap screw. Tighten to 15 ft-lbs.
- C) Position your lifter tube controls onto the smart hook.

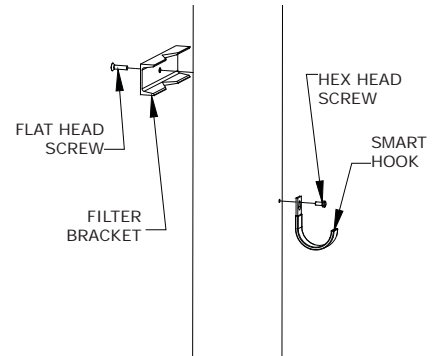

Diagram 6D. Installing Smart Hook

6.5 INSTALLING ROTATION STOPS ON WALL MOUNTED PIVOT PRO® (diagram 6E)

WARNING

Rotation Stops are meant to limit rotation, not stop rotation.

Contact Gorbel® Customer Service at 800-821-0086 for further instructions.

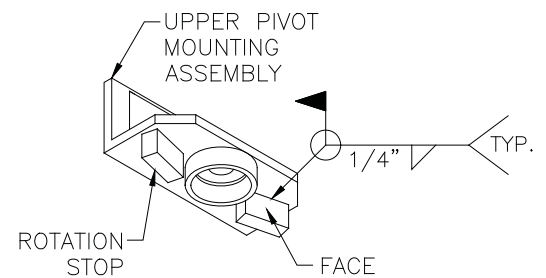

Diagram 6E. Welding rotation stops on the Wall Mounted PIVOT PRO™

STEP 7 - FINAL STEPS

➡ **TIP:** Do not throw away this manual: maintenance schedule is on back cover.

- 7.1 Check to make sure all bolts are tight and lock washers are compressed.
- 7.2 If necessary, touch up crane with paint provided.
- 7.3 Keep Packing List, Installation Manual, General Arrangement Drawing, and any other inserts filed together in a safe place.

LIMITED WARRANTY

It is agreed that the equipment purchased hereunder is subject to the following LIMITED warranty and no other. Gorbel Incorporated ("Gorbel") warrants the manual push-pull Work Station Cranes, Jib Crane, and Gantry Crane products to be free from defects in material or workmanship for a period of ten years or 20,000 hours use from date of shipment. Gorbel warrants the Motorized Work Station Cranes and Jib Crane products to be free from defects in material or workmanship for a period of two years or 4,000 hours use from the date of shipment. Gorbel warrants the G-Force® and Easy Arm™ products to be free from defects in material or workmanship for a period of one year or 2,000 hours use from the date of shipment. This warranty does not cover Gantry Crane wheels. This warranty shall not cover failure or defective operation caused by operation in excess of recommended capacities, misuses, negligence or accident, and alteration or repair not authorized by Gorbel. No system shall be field modified after manufacture without the written authorization of Gorbel, Inc. Any field modification made to the system without the written authorization of Gorbel, Inc. shall void Gorbel's warranty obligation. OTHER THAN AS SET FORTH HEREIN, NO OTHER EXPRESS WARRANTIES, AND NO IMPLIED WARRANTIES, ORAL OR WRITTEN, INCLUDING BUT NOT LIMITED TO THE WARRANTIES OF MERCHANTABILITY OR FITNESS FOR A PARTICULAR PURPOSE, ARE MADE BY GORBEL WITH RESPECT TO ITS PRODUCTS AND ALL SUCH WARRANTIES ARE HEREBY SPECIFICALLY DISCLAIMED. GORBEL SHALL NOT BE LIABLE UNDER ANY CIRCUMSTANCES FOR ANY INCIDENTAL, SPECIAL AND/OR CONSEQUENTIAL DAMAGES WHATSOEVER, WHETHER OR NOT FORESEEABLE, INCLUDING BUT NOT LIMITED TO DAMAGES FOR LOST PROFITS AND ALL SUCH INCIDENTAL, SPECIAL AND/OR CONSEQUENTIAL DAMAGES ARE HEREBY ALSO SPECIFICALLY DISCLAIMED. Gorbel's obligation and Purchaser's or end user's sole remedy under this warranty is limited to the replacement or repair of Gorbel's products at the factory, or at the discretion of Gorbel, at a location designated by Gorbel. Purchaser or end user shall be solely responsible for all freight and transportation costs incurred in connection with any warranty work provided by Gorbel hereunder. Gorbel will not be liable for any loss, injury or damage to persons or property, nor for damages of any kind resulting from failure or defective operation of any materials or equipment furnished hereunder. Components and accessories not manufactured by Gorbel are not included in this warranty. Purchaser's or end user's remedy for components and accessories not manufactured by Gorbel is limited to and determined by the terms and conditions of the warranty provided by the respective manufacturers of such components and accessories.

A) DISCLAIMER OF IMPLIED WARRANTY OF MERCHANTABILITY

Gorbel and Purchaser agree that the implied warranty of merchantability is excluded from this transaction and shall not apply to the goods involved in this transaction.

B) DISCLAIMER OF IMPLIED WARRANTY OF FITNESS FOR PARTICULAR PURPOSE

Gorbel and Purchaser agree that the implied warranty of fitness for particular purpose is excluded from this transaction and shall not apply to the goods involved in this transaction.

C) DISCLAIMER OF EXPRESS WARRANTY

Gorbel's agents, or dealer's agents, or distributor's agents may have made oral statements about the machinery and equipment described in this transaction. Such statements do not constitute warranties, and Purchaser agrees not to rely on such statements. Purchaser also agrees that such statements are not part of this transaction.

D) DISCLAIMER OF SPECIAL, INCIDENTAL AND CONSEQUENTIAL DAMAGES

Gorbel and Purchaser agree that any claim made by Purchaser which is inconsistent with Gorbel's obligations and the warranty remedies provided with Gorbel's products, and in particular, special, incidental and consequential damages, are expressly excluded.

E) DEALER OR DISTRIBUTOR NOT AN AGENT

Gorbel and Purchaser agree that Purchaser has been put on notice that dealer or distributor is not Gorbel's agent in any respect for any reason. Gorbel and Purchaser also agree that Purchaser has been put on notice that dealer or distributor is not authorized to incur any obligations or to make any representations or warranties on Gorbel's behalf other than those specifically set forth in Gorbel's warranty provided in connection with its product.

F) MERGER

This warranty agreement constitutes a final and complete written expression of all the terms and conditions of this warranty and is a complete and exclusive statement of those terms.

G) PAINTING

Every crane (excluding components) receives a quality paint job before leaving the factory. Unfortunately, no paint will protect against the abuses received during the transportation process via common carrier. We have included at least one (1) twelve ounce spray can for touchup with each crane ordered (unless special paint was specified). If additional paint is required, contact a Gorbel® Customer Service Representative at 1-800-821-0086 or 1-585-924-6262.

Title and Ownership:

Title to the machinery and equipment described in the foregoing proposal shall remain with Gorbel and shall not pass to the Purchaser until the full amount herein agreed to be paid has been fully paid in cash.

Claims and Damages:

Unless expressly stated in writing, goods and equipment shall be at Purchaser's risk on and after Seller's delivery in good shipping order to the Carrier. Gorbel shall in no event be held responsible for materials furnished or work performed by any person other than it or its authorized representative or agent.

Cancellations:

If it becomes necessary for the purchaser to cancel this order wholly or in part, he shall at once so advise Gorbel in writing. Upon receipt of such written notice all work will stop immediately. If the order entails only stock items, a flat restocking charge of 15% of the purchase price will become due and payable by Purchaser to Gorbel. Items purchased specifically for the canceled order shall be charged for in accordance with the cancellation charges of our supplier plus 15% for handling in our factory. The cost of material and/or labor expended in general fabrication for the order shall be charged for on the basis of total costs to Gorbel up to the time of cancellation plus 15%.

Returns:

No equipment, materials or parts may be returned to Gorbel without express permission in writing to do so.

Extra Charge Delay: If Purchaser delays or interrupts progress of Seller's performance, or causes changes to be made, Purchaser agrees to reimburse Gorbel for expense, if any, incident to such delay.

Changes and Alterations:

Gorbel reserves the right to make changes in the details of construction of the equipment, as in its judgment, will be in the interest of the Purchaser; will make any changes in or additions to the equipment which may be agreed upon in writing by the Purchaser; and Gorbel is not obligated to make such changes in products previously sold any customer.

Third Party Action:

Should Gorbel have to resort to third party action to collect any amount due after thirty (30) days from date of invoice, the Purchaser agrees to pay collection costs, reasonable attorney's fees, court costs and legal interest.

OSHA Responsibilities:

Gorbel agrees to fully cooperate with Purchaser in the design, manufacture or procurement of safety features or devices that comply with OSHA regulations. In the event additional equipment or labor shall be furnished by Gorbel, it will be at prices and standard rates then in effect, or as may be mutually agreed upon at the time of the additional installation.

Equal Employment Opportunity:

Gorbel agrees to take affirmative action to ensure equal employment opportunity for all job applicants and employees without regard to race, color, age, religion, sex, national origin, handicap, veteran, or marital status. Gorbel agrees to maintain non-segregated work facilities and comply with rules and regulations of the Secretary of Labor or as otherwise provided by law or Executive Order.

INSPECTION AND MAINTENANCE SCHEDULE

GORBEL® PIVOT PRO® INSPECTION AND MAINTENANCE SCHEDULE			
ITEM	COMPONENT	MAINTENANCE	FREQUENCY*
1	Mounting Bolts and Anchor Bolts	Check that lock washers are compressed and nuts tightened to manufacturer's specifications.	Every 500 hours or 3 months
2	Clevis Pin	Check that cotter pin is properly installed. Check that clevis pin is not deformed.	Every 2000 hours or yearly
3	Cam Followers	Check to make sure both rollers have full face contact with pipe. Make sure nylock nuts are tight.	Every 1000 hours or 6 months
4	Pivot Pins	Check that cotter pin, spring pin, and square washer are properly installed so that boom cannot dislodge.	Every 2000 hours or yearly
5	Rotation Limits	Check for deformation. Make sure that bolt is tightened. Replace block if deformed.	Every 1000 hours or 6 months
6	Arm Rotation	Adjust friction brakes to achieve desired rotational resistance.	Every 1000 hours or 6 months
7	Accessory Items	Conduct a general inspection of all accessory items.	Every 1000 hours or 6 months
8	Gorbel® Crane	Conduct a visual inspection of the crane overall.	Every 1000 hours or 6 months
9	Vacuum Tube Lifter	Conduct a visual inspection of the vacuum tube lifter overall.	According to Manufacturer's Requirements

*Federal, state and local codes may require inspection and maintenance checks more often. Please check the federal, state and local code manuals in your area.

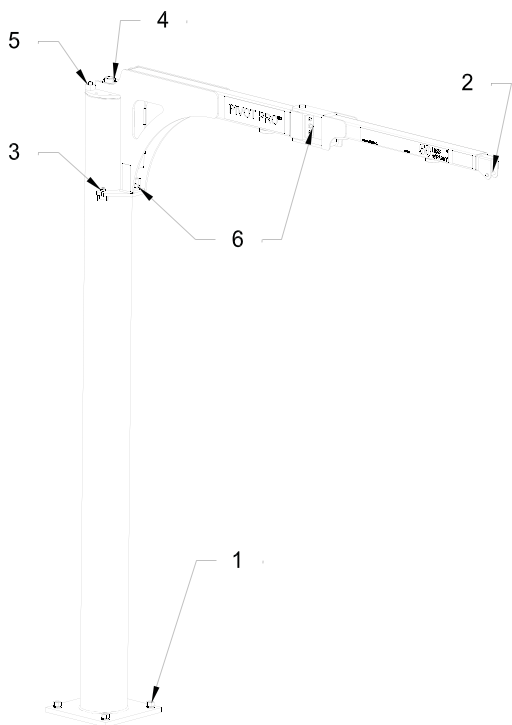

**FREE STANDING
PIVOT PRO®**

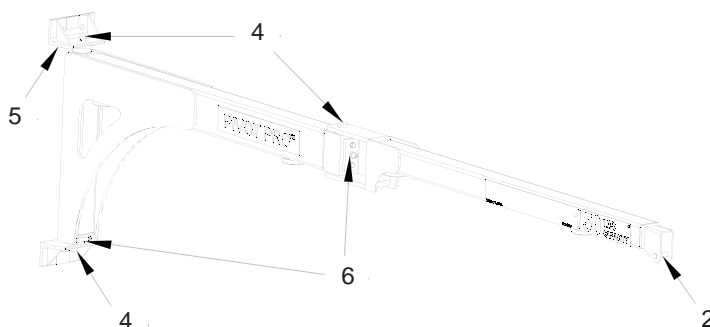

**WALL MOUNTED
PIVOT PRO®**

GORBEL®
A CLASS ABOVE

600 Fishers Run, P.O. Box 593
Fishers, NY 14453-0593
© 2012 Gorbel Inc.
All Rights Reserved

Distributed by Tri-State Equipment Company Inc.

Email: sales@tsoverheadcrane.com

Web: www.tsoverheadcrane.com

PH: 314-869-7200 | FAX: 314-869-7226