

THE INFORMATION CONTAINED IN THIS DRAWING IS THE SOLE PROPERTY OF SUSPA INCORPORATED. ANY REPRODUCTION IN PART OR AS A WHOLE WITHOUT THE WRITTEN PERMISSION OF SUSPA INCORPORATED IS PROHIBITED.

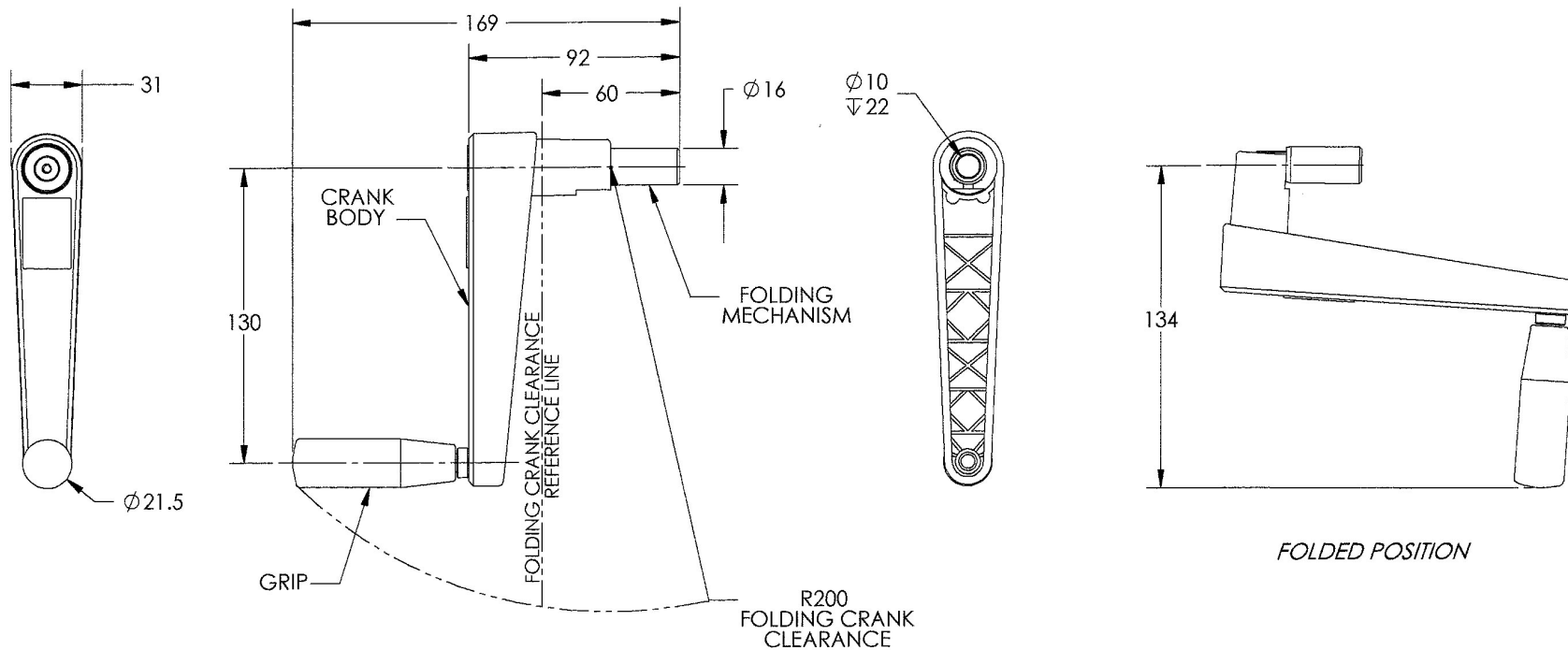

NOTES:

- 1.) ALL DIMENSIONS ARE REFERENCE ONLY.
- 2.) REFERENCE P/N: 644-01027.
- 3.) MATERIAL SPECIFICATIONS:  
 GRIP: BLACK ACETAL.  
 CRANK BODY: MATTE BLACK GLASS FILLED NYLON.  
 FOLDING MECHANISM: STAINLESS STEEL.

**DO NOT MANUFACTURE TO THIS DRAWING UNLESS IT IS MARKED "CONTROLLED"**  
 DO NOT SCALE THIS DRAWING  
 DIMENSIONS ARE IN MILLIMETERS  
 TOLERANCES UNLESS OTHERWISE SPECIFIED  
 ONE PLACE DECIMAL +/-0.2 ANGULAR +/-2°  
 TWO PLACE DECIMAL +/-0.1  
 DRAWN BY: JED DATE: 11/24/04 SCALE: 1:2  
 CUSTOMER DRAWING

REV		REVISIONS		CHANGED BY	APPROVED BY	DATE (MM/DD/YY)
ECON					JED	11/24/04
DESCRIPTION						
130MM RF FOLDING CRANK						
MATERIAL						
N/A						
DRAWING NUMBER						
S44-0009						
				3970 Roger B. Chaffee S.E. Grand Rapids, Michigan 49548-3497		DRAWING SIZE
						B