

THE INFORMATION CONTAINED IN THIS DRAWING IS THE SOLE PROPERTY OF SUSPA INCORPORATED. ANY REPRODUCTION IN PART OR AS A WHOLE WITHOUT THE WRITTEN PERMISSION OF SUSPA INCORPORATED IS PROHIBITED.

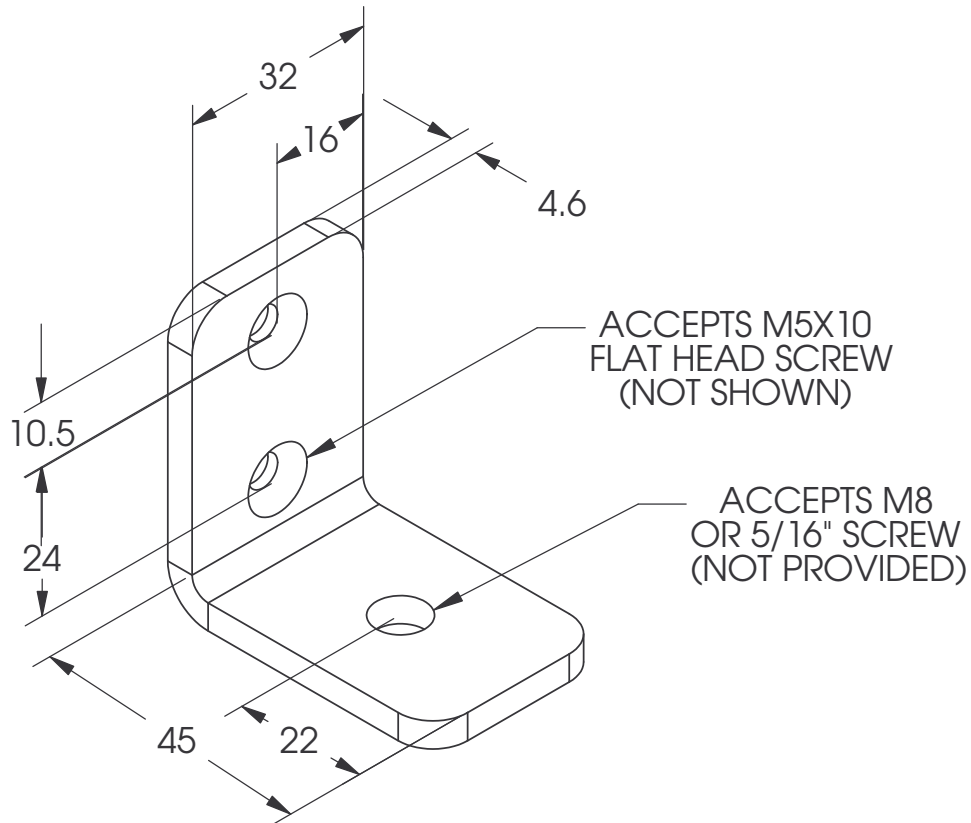

**NOTES:**

- 1.) ALL DIMENSIONS ARE REFERENCE ONLY.
- 2.) BRACKET MATERIAL: STEEL WITH ZINC PLATING AND A CLEAR TRIVALENT CHROMATE CONVERSION COATING.
- 3.) EXTRUSION BRACKET KIT (P/N: D44-00018) INCLUDES:  
(2) - MOUNTING BRACKETS, AND  
(4) - M5X10 FLAT HEAD SCREWS.

A	8371	PLATING WAS BLACK CHROMATE COATING	AJB	JED	7/31/06
				JED	11/29/04
REV	ECN	REVISIONS	CHANGED BY	APPROVED BY	DATE (MM/DD/YR)

DESCRIPTION: EXTRUSION MOUNTING BRACKET (FOR CB CYLINDERS)

MATERIAL: N/A

DRAWING NUMBER: S44-0012A

			3970 Roger B. Chaffee S.E. Grand Rapids, Michigan 49548-3497	DRAWING SIZE <b>A</b>
--	--	--	---	--------------------------

**DO NOT MANUFACTURE TO THIS DRAWING UNLESS IT IS MARKED "CONTROLLED"**

**DO NOT SCALE THIS DRAWING DIMENSIONS ARE IN MILLIMETERS TOLERANCES UNLESS OTHERWISE SPECIFIED**

ONE PLACE DECIMAL	+/-0.2	ANGULAR	+/-2°
TWO PLACE DECIMAL	+/-0.1		

DRAWN BY JED	DATE 11/29/04	SCALE 1:1	THIRD ANGLE PROJECTION
-----------------	------------------	--------------	------------------------

**CUSTOMER DRAWING**