

NOTES:

- 1) ALL DIMENSIONS SHOWN ARE REFERENCE.
- 2) SWITCH P/N: 645-03102 SHOWN INCLUDES SWITCH, SWITCH MOUNTING PLATE, AND 3 MOUNTING SCREWS.
- 3) ERGONOMICALLY DESIGNED WITH SOFT-TOUCH PADS
- 4) 4 MEMORY PRESETS ARE PROVIDED FOR STORING AND RECALLING DIFFERENT POSITIONS.
- 5) THE 3-DIGIT LED DISPLAY CAN BE CONFIGURED IN STANDARD OR METRIC.
- 6) UNIQUE SLIDE MECHANISM ALLOWS SWITCH TO SLIDE UNDER WORK SURFACE WHEN NOT IN USE.
- 7) CUSTOM SWITCH APPLIQUE DESIGNS ARE AVAILABLE UPON REQUEST.
- 8) OPERATING VOLTAGE: 5 VDC.
- 9) OPERATING TEMPERATURE: 0° - 50°C.
- 10) PROTECTION TYPE: IP 32.
- 11) WEIGHT: 0.3 KG.

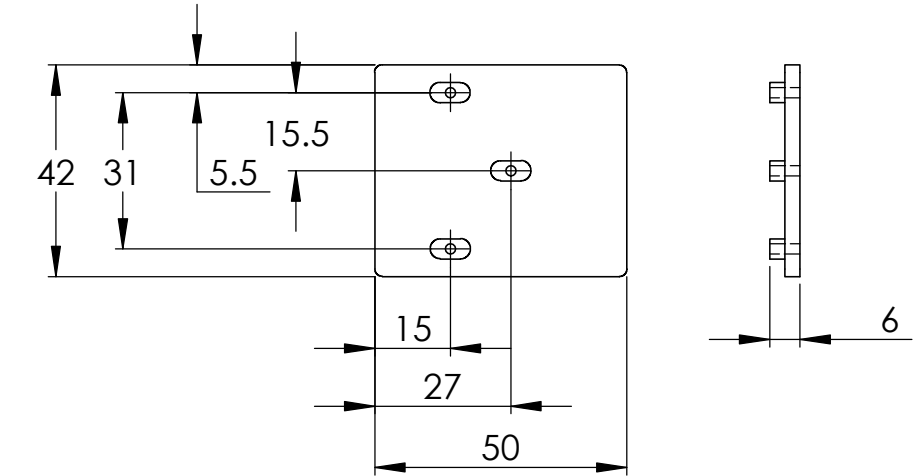

MOUNTING PLATE  
DETAIL

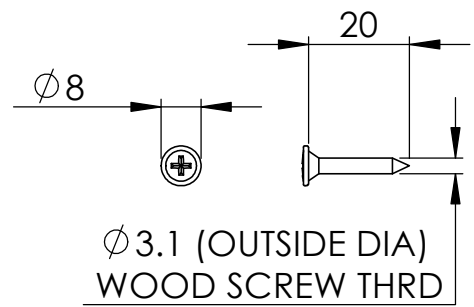

MOUNTING SCREW  
DETAIL

UNLESS OTHERWISE STAMPED THIS DRAWING IS UNCONTROLLED -DO NOT BUILD FROM- ALL PARTS CALLED OUT IN SUBASSEMBLIES ARE BASE NUMBERS. SEE SHOP PACK FOR REV LEVEL

METRIC DRAWING - DO NOT SCALE -		
TOLERANCES U.O.S.		
+/-0.2	ONE PLACE DECIMAL	+/-2° ANGLES
+/-0.1	TWO PLACE DECIMAL	
DRAWN BY C BELTMAN	DATE 4/19/01	SCALE NO SCALE

CUSTOMER DRAWING

REV	CHANGE	CHANGED BY	APPROVED BY	DATE
EC#				
DESCRIPTION SWITCH, DISPLAY, MEMORY, UP/DOWN				
MATERIAL BLACK ABS (RAL 9005)				
DRAWING NUMBER S45-1008				
				DRAWING SIZE B
3970 Roger B. Chaffee S.E. Grand Rapids, Michigan 49548-3497				