



U_B SERIES

PNEUMATIC CABLE BALANCER

CAPACITY UP TO 485LB, SINGLE-REEVED

The Unified pneumatic balancer is a perfect choice when transferring loads that require more precision than a pneumatic hoist. Simple to adjust UP/DN speeds and "float" mode gives you more accuracy to finish the job.

BENEFITS & FEATURES

LOAD SAFETY

Check valve in case of loss of air supply.

ENERGY EFFICIENT

Only a fraction of CFM per cycle when compared to a pneumatic hoist.

LONGER SERVICE LIFE

Robust precision mechanical design & powder-coated housing ensures trouble free extended life.

OTHER FEATURES

Uses non-lubricated air, assures clean environment.

All non-reeved balancers come equipped with a 9 meter cable.

CONTROL STYLES

UBB = Basic Balancer with no controls
 UAB = Balancer with Up/Down controls
 UZB = Balancer with Zero-G controls





UNIFIED

PNEUMATIC CABLE BALANCER

U_B-132 SERIES

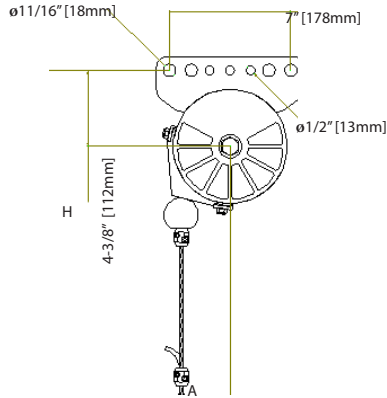

U_B-220,331 SERIES

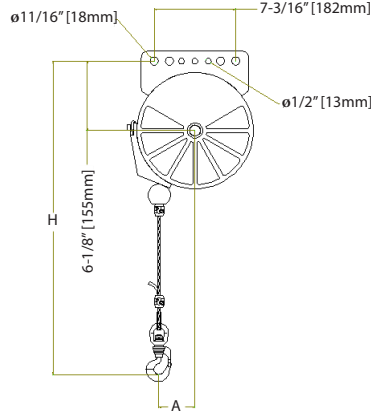

U_B-485 SERIES

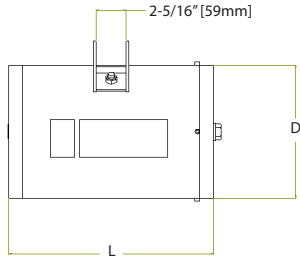
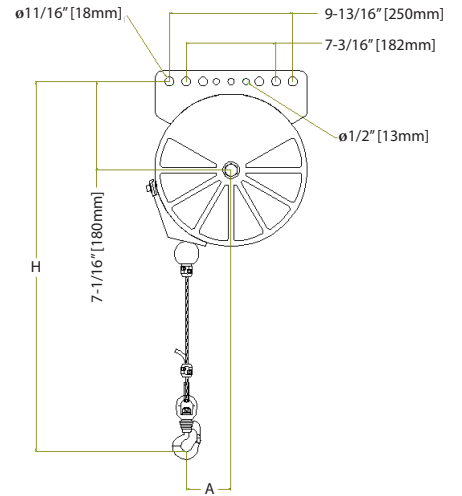

REEVED SERIES

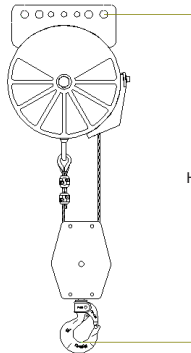

TANDEM SERIES

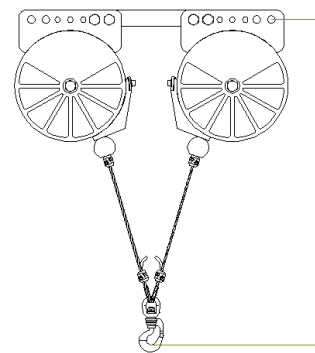

Model #	"A" Dimension
U_B-132-079	2.83 inch (72mm)
U_B-220-118	4.35 inch (110.5mm)
U_B-331-079	2.83 inch (72mm)
U_B-485-079	2.83 inch (72mm)

Wire Rope Units (Air Pressure 7kgf/cm2) (100 PSI)

Model#	Capacity		Lift		D x L		H		Net Weight		CFM
	lbs	kg	in	mm	in	mm	in	mm	lbs	kg	(per cycle)
U_B-132-079	132	60	79	2000	6.1 x 15.43	155 x 392	23	600	51	23	0.5
U_B-220-118	220	100	118	3000	10.24 x 15.75	260 x 400	28	700	94	42.5	1.3
U_B-331-079	331	150	79	2000	10.24 x 15.75	260 x 400	28	700	105	47	1.3
U_B-485-079	485	220	79	1950	12.21 x 15.75	310 x 400	30	750	110	50	1.9
U_B-440-59R	440	200	59	1500	10.24 x 15.75	260 x 400	28	700	104	47	
U_B-662-39R	662	300	39	1000	10.24 x 15.77	260 x 400	28	700	99	45	
U_B-970-39R	970	440	39	1000	12.21 x 15.75	310 x 400	30	750	124	56	
U_B-440-118T	440	200	118	3000	2-10.24 x 15.76	260 x 400	28	700	203	92	
U_B-661-79T	662	300	79	2000	2-10.24 x 15.78	260 x 400	28	700	198	90	
U_B-970-79T	970	440	79	2000	2-12.21 x 15.75	310 x 400	30	750	243	110	

Optional Items:

Model #	Description
99025	Up/Down Manifold
99026	Up/Down Control Kit - includes: manifold, 12' Hose and 2-Button pendant
99101	2-Button Up/Dn Pendant Control
99100	Top Hook Assembly



UNIFIED INDUSTRIES, INC.

A Columbus McKinnon Company

Distributed by Tri-State Equipment Company Inc.
 sales@tsoverheadcrane.com
 www.tsoverheadcrane.com
 Tel: (314) 869-7200